

Catalogo visibilità

Visibility catalogue

36^A EDIZIONE, 10-12 OTTOBRE 2018
RIMINI FIERA, ITALIA



SUN

BEACH&OUTDOOR STYLE



PLANiSPHERE
The Italian marketplace for travel & hospitality

**TTC**
TRAVEL
EXPERIENCE

**SIA**
HOSPITALITY
DESIGN

**SUN**
BEACH&OUTDOOR
STYLE

ORGANIZZATO DA **ITALIAN EXHIBITION GROUP**
Providing the future

Energia al tuo business

Ecco cosa fare prima,
durante e dopo la fiera.

Power to your business

What to do before,
during & after the trade show

PRIMA
BEFORE



DURANTE
DURING



DOPO
AFTER

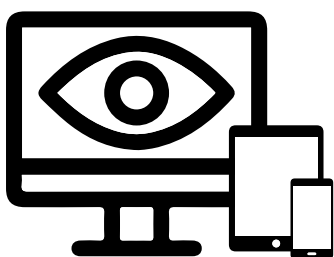

Visibilità sul sito web
Visibility on the website

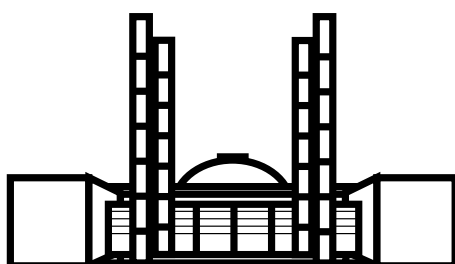

Pubblicità nel quartiere fieristico
Visibility in the exhibition centre

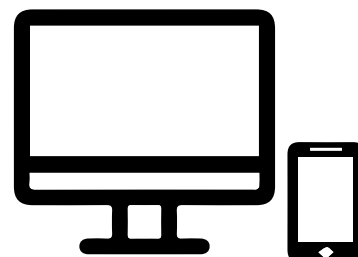

Visibilità sul sito web
Visibility on the website

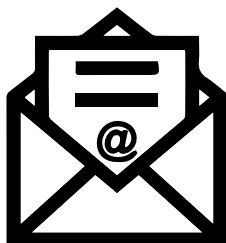

Newsletter, DEM

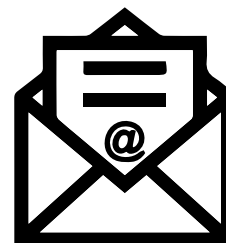

SUN
BEACH&OUTDOOR
STYLE



Newsletter, DEM

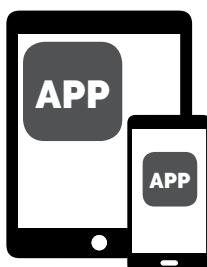

Pubblicità sugli inviti
Advertising on the invitation



Pubblicità sulla APP
Advertising on APP



DEM post show



Strumenti di Marketing

Marketing tools

COMUNICA CON
I TUOI CLIENTI
TUTTO L'ANNO

COMMUNICATE WITH
YOUR CUSTOMERS
ALL THE YEAR

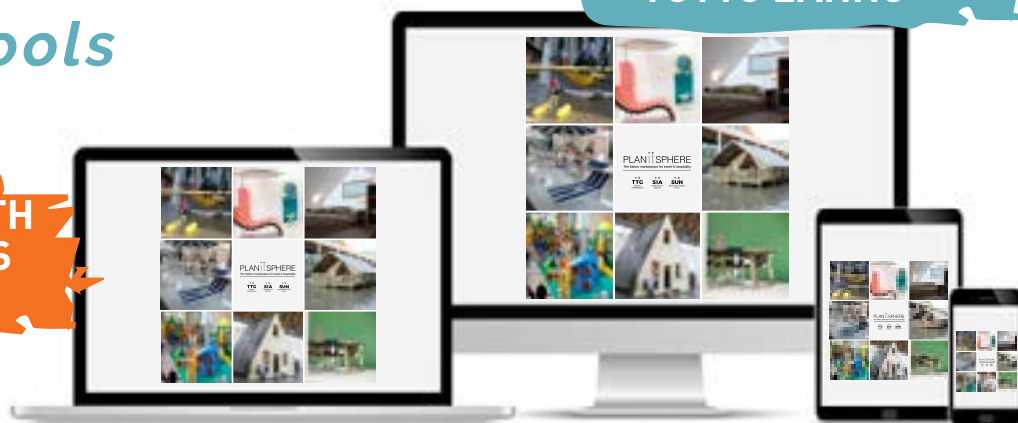

- 1 Home page BANNER A REFRESH
Home page SPONSOR
- 2 BANNER SPONSOR
Sezioni interne
- 3 Personalizzazione PDF BADGE
- 4 Spot nella VIDEO GALLERY
- 5 Newsletter VISITATORI
- 6 DEM: una newsletter
tutta dedicata a te
- 7 Pubblicità sull'INVITO WEB
- 8 Spot sulla APP
ufficiale di manifestazione

- 1 Homepage REFRESH BANNER
Home page SPONSOR
- 2 SPONSOR BANNER
Internal section
- 3 PDF BADGE Personalisation
- 4 Advert in the VIDEO GALLERY
- 5 VISITOR Newsletter
- 6 DEM: a newsletter completely
dedicated to you
- 7 Advertising on the INVITATION WEB
- 8 Advertising on official APP
for the exhibition



Pubblicità sul **SITO WEB** / Advertising on the **WEBSITE**



BANNER su home page

Il logo della tua azienda a refresh sulla HOME PAGE di www.sungiosun.it

I VANTAGGI

Spazio prestigioso per offrire il benvenuto a tutti i visitatori del sito

Formato:

300x100 pixel gif o Jpg 72 dpi), con il relativo link al sito.

Refresh homepage **BANNER**

Refresh advertising on the en.sungiosun.it HOMEPAGE

THE ADVANTAGES

A prestigious space for welcoming all visitors to the site

Formato:

300x100 pixels (gif or Jpg 72 dpi),
with corresponding link to site.

Prezzo / Price

€ 300,00

cad./each

Italian - English

+ iva a settimana - per week



BANNER SPONSOR sezione visitatori SPONSOR BANNER visitors section

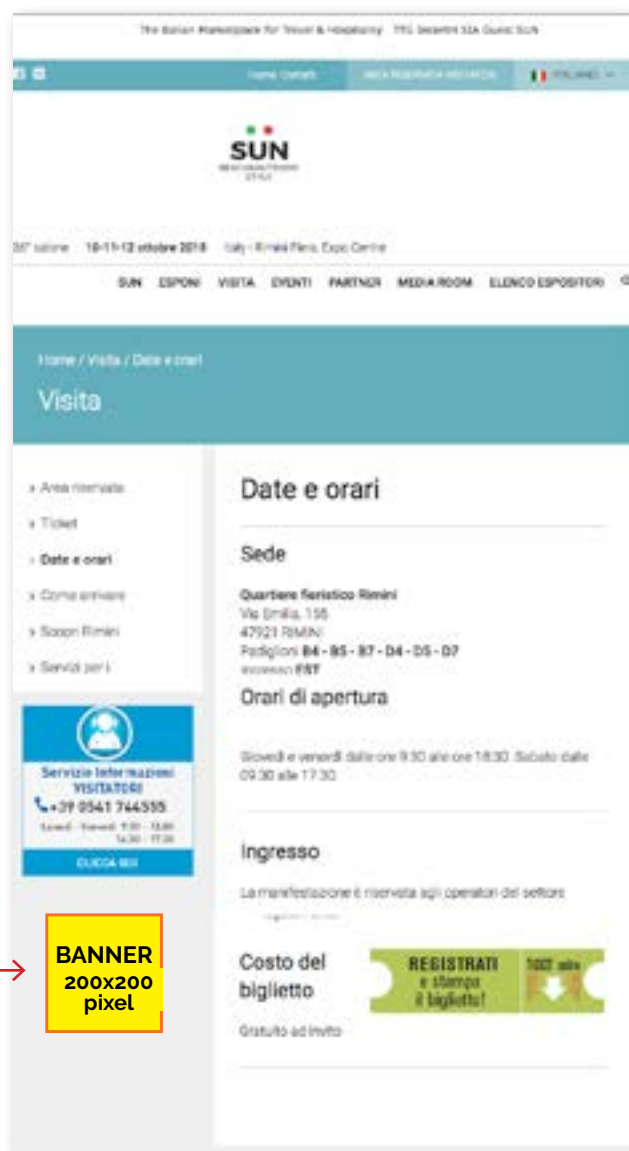

Publicità inserita nella sezione riservata ai visitatori: dove è possibile scaricare il biglietto e trovare tutti gli strumenti per organizzare al meglio la visita (eventi ed espositori preferiti, bus navetta, ecc).

I VANTAGGI

- Spazio fisso a te dedicato nell'area riservata che ti consente di raggiungere tutti i potenziali clienti mentre stampano il biglietto e organizzano la propria visita in fiera.

Formato:

200x200 pixel (gif o Jpg 72 dpi). con il relativo link al sito.

160X80 pixel (gif o Jpg 72 dpi).

con il relativo link al sito.

Prezzo / Price

€ 300,00

cad./each
Italian - English

+ iva a settimana - per week

Advertising located in the visitors section: here they download the ticket and find all the tools for the best organisation of the visit (favourite events and exhibitors, shuttle bus, etc.).

THE ADVANTAGES

Fixed space in the reserved area that lets you reach all potential clients while they print the ticket and organise their visit to the exhibition.

Format:

200x200 pixels (gif or Jpg 72 dpi), with corresponding link to site.

160X80 pixel (gif or Jpg 72 dpi).

with corresponding link to site.

Prezzo / Price

€ 300,00

cad./each
Italian - English

+ iva al settimana - per weel



Personalizzazione PDF BADGE PDF BADGE personalisation

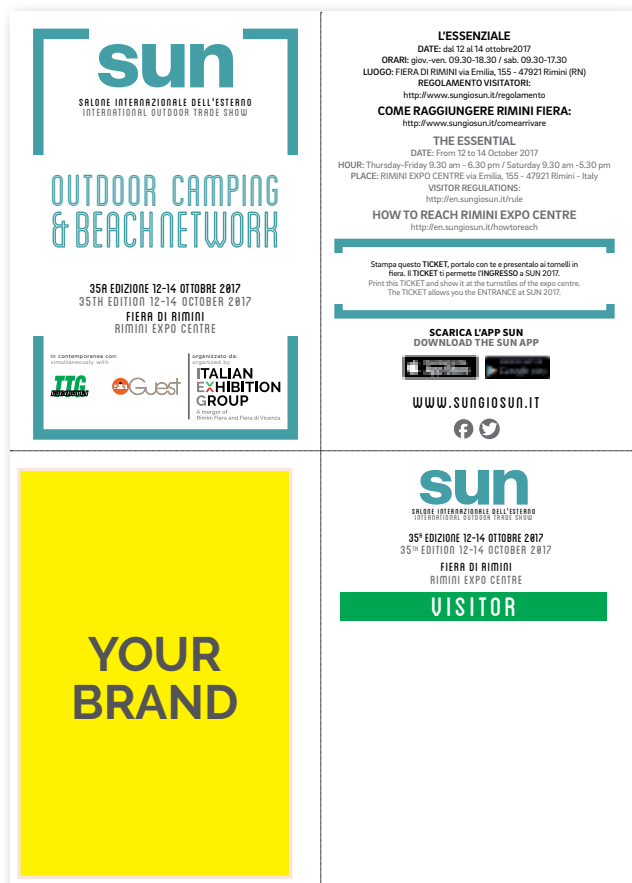

Visibilità del marchio aziendale sul badge pdf d'ingresso che viene generato durante il preaccredito online (90% dei badge totali).

Materiale grafico: logo in formato jpg o gif (300 dpi).

Consegna materiale: via e-mail all'indirizzo jeancarlos.rios@iegexpo.it

Prezzo / Price

€ 6.000,00

cad./each
Italian - English

+ iva

Corporate brand visibility on the pdf badge to enter the fair that is issued to all registered on the web site (90% of the total badges).

Graphic materials: logo in jpg or gif (300dpi) format.

Delivery of material:

By e-mail to the address jeancarlos.rios@iegexpo.it



Spot nella VIDEO GALLERY / Advert in the VIDEO GALLERY

I VANTAGGI

• Promuovere il tuo spot o video aziendale verso tutti gli operatori del settore.

Formato:

Link del video caricato su YOUTUBE oppure inviare il file del video in formato MPEG oppure MOV mediante un WETRANSFER.

THE ADVANTAGES

• Push your company promo with all operators in the sector.

Format:

Link to video uploaded to YOUTUBE or send the video file in MPEG or MOV format via WETRANSFER.

Prezzo / Price

€ 4.000

cad.
each.

+ iva

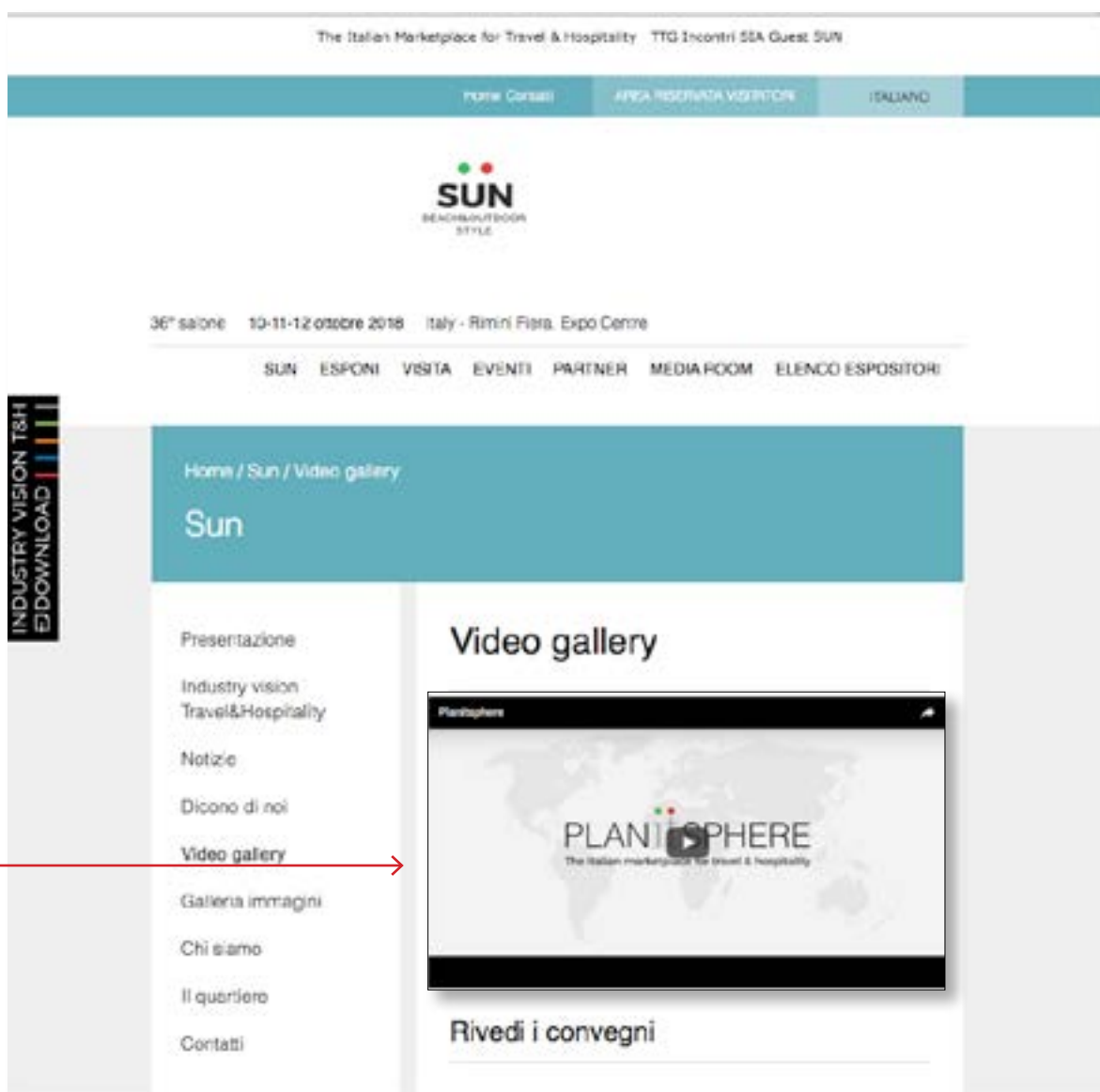

newsletter **VISITATORI/ VISITOR** Newsletter

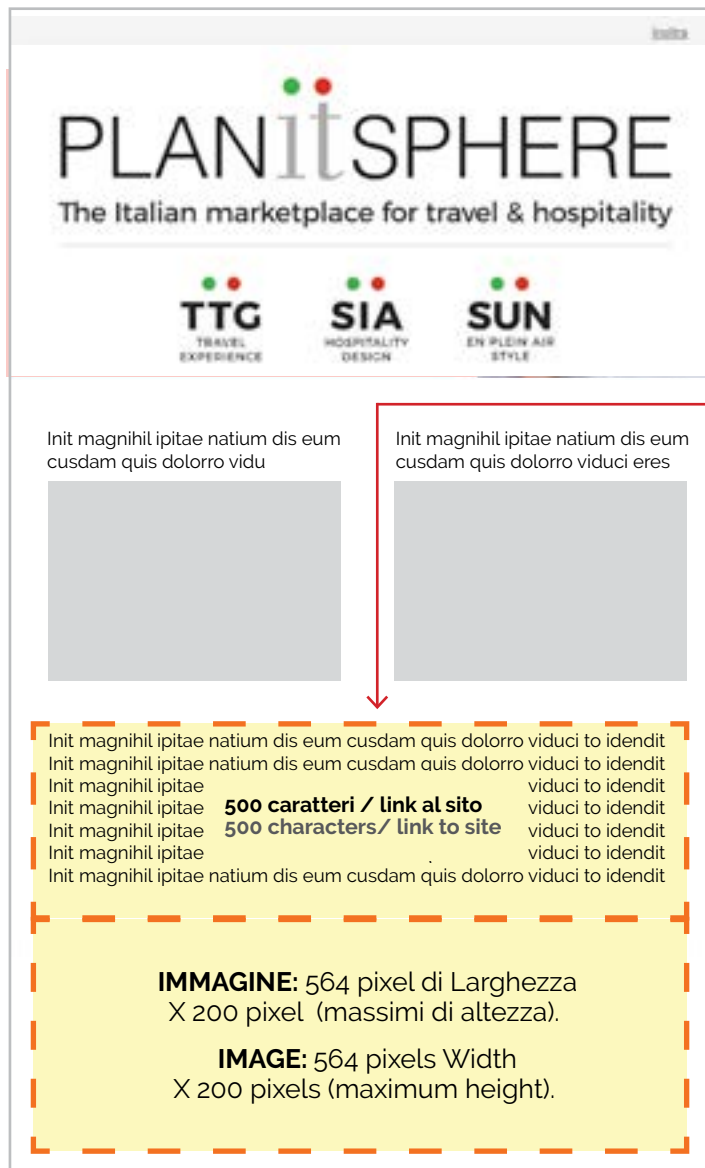

NEWSLETTER

Inserimento del tuo spazio pubblicitario all'interno di una newsletter di **SUN BEACH & OUTDOOR STYLE** inviata a oltre 60.000 operatori di settore nel mondo.

I TUOI VANTAGGI

• raggiungi i tuoi potenziali clienti in ufficio, su tablet e smartphone in qualunque momento

Lingue: italiano o inglese

Prezzo / Price € 3.000,00 + iva a spedizione.

Formato:

1 IMMAGINE 564x200 pixel base x altezza (gif o Jpg 72 dpi)
1 Notizia di 500 caratteri spazi inclusi con il relativo link al sito.

Solo banner

Formato: 300x250 pixel 500€ cad.

Prezzo / Price

€ 3.000,00 cad. each.

+ iva

Italian - English

Prezzo / Price

Solo Banner Only banner
€ 500,00 cad. each.

+ iva

Italian - English

NEWSLETTER

Addition of your advertising space in a delivery of the **SUN BEACH & OUTDOOR STYLE** newsletter, sent to over 60,000 sector operators worldwide.

THE ADVANTAGES FOR YOU

• Reach your potential clients in the office and on their tablets and smartphones at any time.

Languages: Italian or English

Format:

- 1 564x200-pixel IMAGE width x height (gif or Jpg 72 dpi)
- 1 News Item of 500 characters including spaces with corresponding link to site.

Only banner

Format: 300x250 pixel 500€ each.



DEM: una newsletter tutta dedicata a te
DEM: a Newsletter completely dedicated to you

DEM PERSONALIZZATA
PERSONALISED DEM

I TUOI VANTAGGI

- Uno spazio dedicato esclusivamente alla promozione del tuo brand e dei tuoi prodotti.
- i tuoi potenziali clienti potranno leggere il tuo messaggio dall'ufficio, su tablet e smartphone.

Lingue: italiano o inglese

Formato: html realizzato dall'espositore oppure inviando 1 logo dell'azienda, un testo di descrizione e delle immagini.

Materiale: fi le zip contenente l'html e le immagini collegate, larghezza

600 pixel; peso per immagine 250 kb.

File non supportati: fl ash, video, gif animate e css esterni.

Consegna materiale: via e-mail a jeancarlos.rios@iegexpo.it

Prezzo / Price

€ 1.500,00 cad.
each.

+ iva a spedizione - per delivery

THE ADVANTAGES FOR YOU

- A space dedicated solely to the promotion of your brand and your products.
- Your potential clients can read your message from the office and on their tablets and smartphones.

Languages: Italian or English

Format: html produced by the exhibitor or by sending 1 company logo, a descriptive text for the photographs.

Graphic materials: Zip fi le contains the html fi le and corresponding images;

width 600 pixel, weight 250 kb each image.

Files in fl ash, video, animated gifs and external css are not allowed.

Delivery of material: By e-mail at jeancarlos.rios@iegexpo.it



Pubblicità sull' INVITO WEB Advertising on the WEB INVITATION

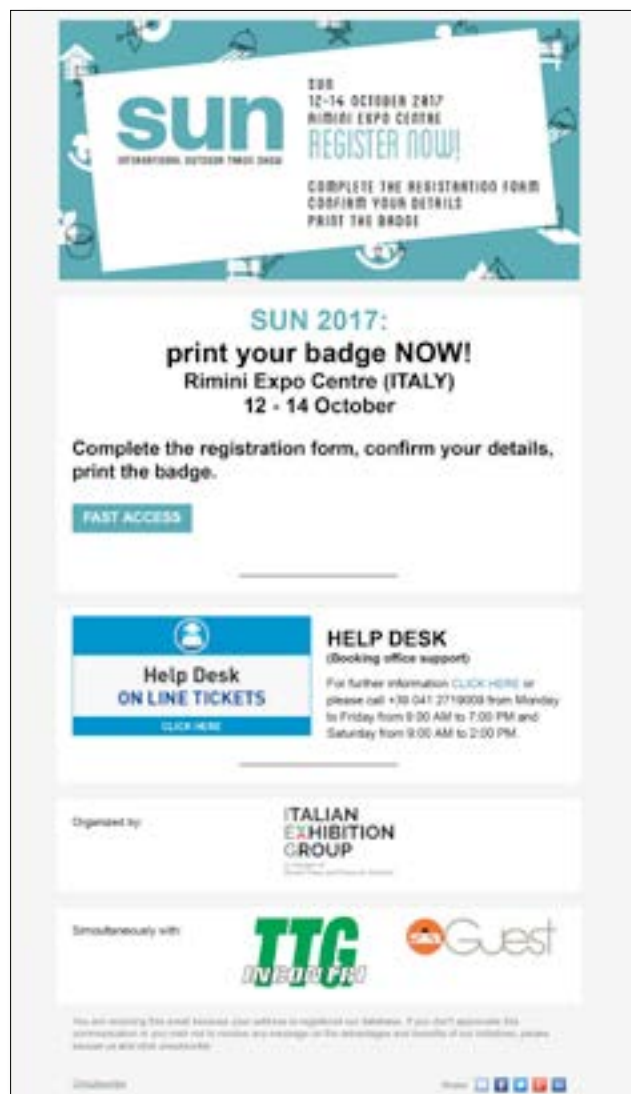

BANNER 564x200 pixel
(base x altezza gif o Jpg 72 dpi),
con il relativo link al sito.

BANNER 564x200 pixels
(width x height gif or jpg 72 dpi),
with its link to the site.

Banner con il link al sito della tua azienda, inserito sull'**INVITO WEB**, che **SUN BEACH & OUTDOOR STYLE** invia ad una selezione esclusiva di operatori professionali.

I TUOI VANTAGGI

Il tuo banner viene inserito sull'invito che **SUN BEACH & OUTDOOR STYLE** invia via email nel mese di novembre ad una selezione esclusiva di 60.000 operatori professionali nel mondo.

Formato:

banner 564x200 pixel (base x altezza gif o Jpg 72 dpi), con il relativo link al sito.

Prezzo

€ 6.000,00

Italia + iva

Banner with the link to your company, on the **WEB INVITATION**, which **SUN BEACH & OUTDOOR STYLE** sends to a exclusive selection of professional operators.

THE ADVANTAGES FOR YOU

Your banner is added to the invitation that **SUN BEACH & OUTDOOR STYLE** e-mails in November to a exclusive selection of 60,000 professional operators worldwide.

Format:

564x200-pixel banner (width x height gif or Jpg 72 dpi), with corresponding link to site.

Price €10,000.00 + vat



Banner sulla **APP** ufficiale di manifestazione
Banner on the official **APP** for the exhibition



I VANTAGGI

- Promuovere il tuo brand e la tua posizione in fiera verso tutti gli operatori del settore che scaricano e utilizzano la **APP** in occasione della manifestazione.

Prezzo / Price

€ 6000,00

cad.
each.

+ iva

Italian - English

THE ADVANTAGES

- Promote your brand and your position in the exhibition with all operators in the sector who download and use the **APP** at the exhibition.



PUBBLICITÀ NEL QUARTIERE FIERISTICO



VISIBILITY IN THE EXHIBITION CENTRE



**FATTI VEDERE
E TROVARE
IN FIERA!**

**SHOW YOURSELF
AT THE FAIR!**

- A Pannelli rotanti esterni**
Outdoor multivision rotating billboards
AREE INGRESSI: SUD n.8 - OVEST n.4 - EST n.2
- B Telo ponte ferrovia**
Railway bridge banner
INGRESSO SUD
- C Cigni esterni**
External "swan" panel stands
VIALE INGRESSO SUD / SOUTH ENTRANCE DRIVE
- D Teli fontana ingresso sud**
Banners fountain south entrance
INGRESSO SUD / SOUTH ENTRANCE DRIVE
- E Telo pubblicitario sottopasso pedonale**
Underpass advertising banner
VIALE INGRESSO SUD / SOUTH ENTRANCE DRIVE
- F Totem bifacciali (stazione di Rimini Fiera)**
Double-sided Totem
(in Rimini Fiera train station)
STAZIONE FERROVIARIA INGRESSO SUD
RAILWAY STATION SOUTH ENTRANCE
- G Teli palazzine ingresso sud**
South office building banner
INGRESSO SUD PALAZZINE UFFICI
SOUTH ENTRANCE OFFICE BUILDING
- H Teli ingresso Est-ovest**
East-west entrance Banner
AREA ESTERNA INGRESSI EST-OVEST
EAST-WEST ENTRANCES OUTDOOR AREAS
- I Aree interne ed esterne/gonfiabili**
Internal and external areas/inflatables
- J Personalizzazione vetrate padiglioni**
Pavilions Windows personalization



**FATTI VEDERE
E TROVARE
IN FIERA!**

**SHOW YOURSELF
AT THE FAIR!**

- K Teli colonne interne**
Internal column banners
INGRESSI E AREE INTERNE - ENTRANCES AND INDOOR AREAS
- L Vele esterne ed interne**
External and Internal "sail" panel stands
AREE INTERNE ED ESTERNE
INDOOR AND OUTDOOR AREAS
- M Personalizzazione tornelli d'ingresso**
Entrance turnstiles personalization
INGRESSI SUD-EST-OVEST
SOUTH-EAST-WEST ENTRANCES
- N Cigni interni**
Internal "swan" panel stands
INGRESSI SUD - OVEST - EST
ENTRANCE SOUTH - EAST- WEST
- O Teli pubblicitari hall sud**
South hall advertising banners
INGRESSI SUD - ENTRANCE SOUTH
- P Teli pubblicitari area Caffè**
Coffee area advertising Banners
AREA BAR E NEGOZI INGRESSI - HALL CENTRALE
BAR AND SHOPPING AREA ENTRANCES
AND CENTRAL FOYER
- P₁ Adesivo area hall SUD**
South hall floor sticker
- Q Adesivi pubblicitari su pavimento**
Adhesive floor graphics
AREE INTERNE I / INDOOR AREAS
- S Teli in pvc porticato piscine**
Pool portico Pvc banners
AREA PISCINE / POOL AREA
- S₁ Stendardo padiglione**
Banner pavilion

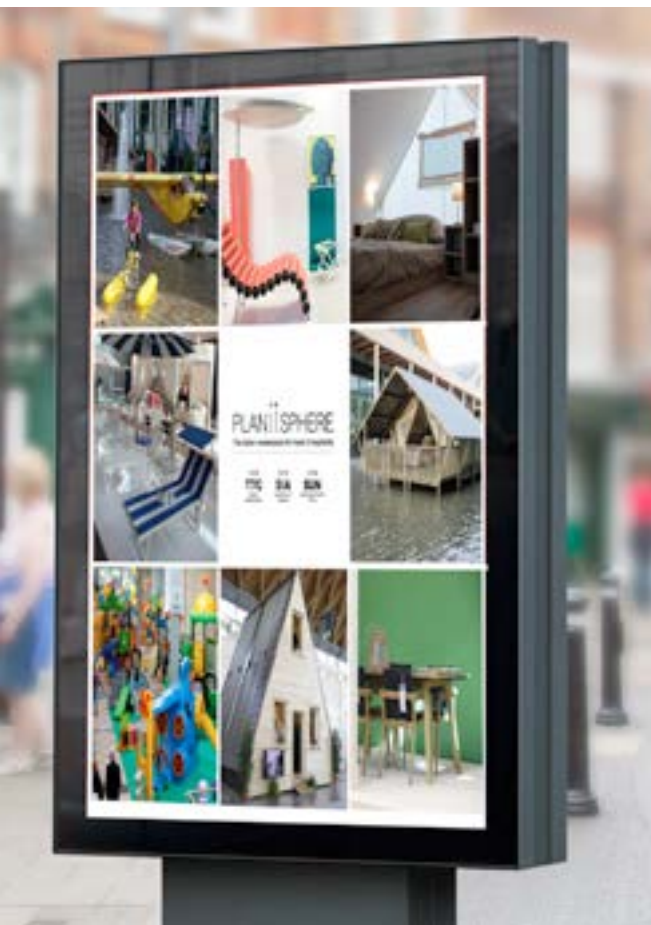

**FATTI VEDERE
E TROVARE
IN FIERA!**

**SHOW YOURSELF
AT THE FAIR!**

T Piscine interne

Internal pools

U Spot pubblicitario su maxischermo

Advertising spot on videowall

HALL CENTRALE E AREE SELF-SERVICE
CENTRAL FOYER AND SELF-SERVICE AREAS

V Personalizzazione scalinate

Step/stair branding

INGRESSI SUD - EST - OVEST - HALL CENTRALE
SOUTH - EAST - WEST ENTRANCES - CENTRAL FOYER

W Personalizzazioni porte girevoli

Swing door branding

INGRESSI SUD - EST - OVEST - HALL CENTRALE
SOUTH - EAST - WEST ENTRANCES - CENTRAL FOYER

X Personalizzazione colonne

Column branding

HALL CENTRALE INGRESSI SUD - EST - OVEST, PISCINE
CENTRAL FOYER - SOUTH - EAST - WEST ENTRANCES, POOLS



A Pannelli rotanti esterni Multivision rotating billboards

AREE INGRESSI: SUD n.8 - OVEST n.4 - EST n.2
ENTRANCE AREA: SOUTH n.8 - WEST n.4 - EAST n.2

Visibilità del brand / pubblicità aziendale sui pannelli rotanti posti agli ingressi della fiera.

Multivision rotating billboards near the expo centre entrances.



500 cm x 300 cm (bxh).
500 cm x 300 cm (width x height).

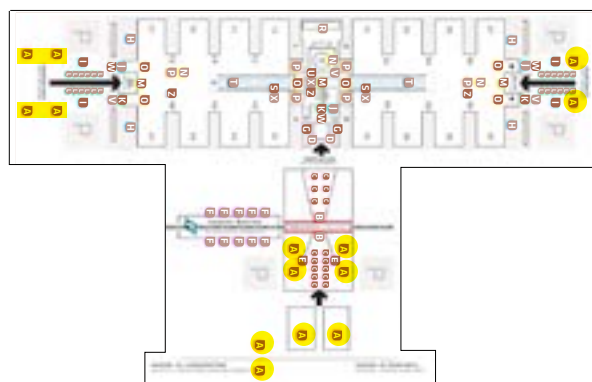

Quotazione / Price

€ 6.100,00 cad. each.

+ iva

Comprensivo di visibilità, produzione, posizionamento e rimozione.

Including visibility, production, placement and removal.

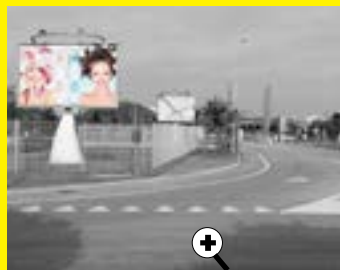

 *Clicca per ingrandire*
Click to enlarge

OPZIONA PRIMA DEGLI ALTRI IL TUO SPAZIO!
OPTION YOUR SPACE BEFORE OTHER!



pag_16

Dimensione: **500 cm x 300 cm (bxh)**
Materiale grafico: **file in PDF alta risoluzione fornito dal cliente.**
Consegna materiale: **entro il 01 settembre 2018**
e-mail a: jeancarlos.rios@iegexpo.it

Size: **500 cm x 300 cm (width x height).**
Graphic materials: **High-resolution PDF file format supplied by the customer.**

Delivery of material: **By e-mail to the address**
jeancarlos.rios@iegexpo.it not later than **September 1st, 2018.**

B Telo ponte ferrovia
Railway bridge banner
INGRESSO SUD n.2 Teli

Visibilità del brand / azienda
su teli collocati sui lati del
ponte della ferrovia (telo in
pvc inserito su telaio).

Corporate brand visibility on
banners placed on the railway
bridge (pvc sheet in frame work).

**YOUR
BRAND**

12 m x 1,50 m (bxh). • 12 m x 1,50 m (width x height).

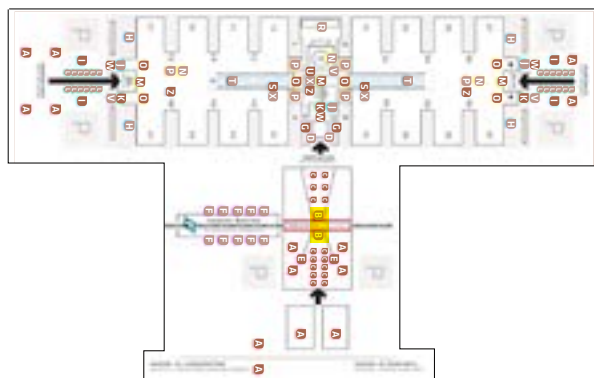

Quotazione / Price

€ 5.000,00 cad.
each.

+ iva

Comprensivo di visibilità, produzione,
posizionamento e rimozione.

*Including visibility, production,
placement and removal.*



 *Clicca per ingrandire*
Click to enlarge

OPZIONA PRIMA DEGLI ALTRI IL TUO SPAZIO!
OPTION YOUR SPACE BEFORE OTHER!



pag_17

Dimensione: **12 m x 1,50 m (bxh)**
Materiale grafico: **file in PDF alta risoluzione fornito dal cliente.**
Consegna materiale: **entro il 01 settembre 2018**
e-mail a: jeancarlos.rios@iegexpo.it

Size: **12 m x 1,50 m (width x height)**
Graphic materials: **High-resolution PDF file format supplied
by the customer.**
Delivery of material: **By e-mail to the address
jeancarlos.rios@iegexpo.it not later than September 1st, 2018.**

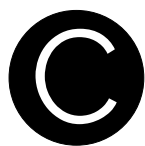

Cigni esterni VIALE INGRESSO SUD

External "swan" stands for double-sided banners

SOUTH ENTRANCE DRIVE

N. 16 Cigni - Outdoor "swan" stands for double-sided banners

Visibilità del brand aziendale sui cigni fissi posizionati lungo il viale di ingresso principale (sud).

Corporate brand visibility on the outside fixed signs located along the way of the main entrance (south).



100 cm x 132 cm (bxh).
100 cm x 132 cm (width x height).

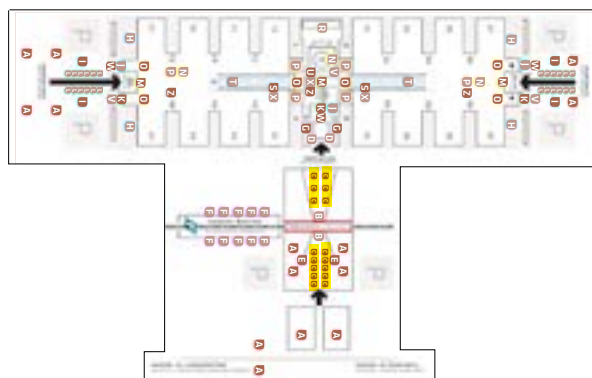

Quotazione / Price
10 CIGNI

€ 10.000,00

6 CIGNI

€ 6.000,00

+ iva

Comprendente di visibilità, produzione, posizionamento e rimozione

Including visibility, production, placement and removal.



 *Clicca per ingrandire*
Click to enlarge

OPZIONA PRIMA DEGLI ALTRI IL TUO SPAZIO!
OPTION YOUR SPACE BEFORE OTHER!



pag_18

Dimensione: **100 cm x 132 cm (bxh)**
Materiale grafico: **file in PDF alta risoluzione fornito dal cliente.**
Consegna materiale: **entro il 01 settembre 2018**
e-mail a: jeancarlos.rios@iegexpo.it

Size: **100 cm x 132 cm (width x height).**
Graphic materials: **High-resolution PDF file format supplied by the customer.**
Delivery of material: **By e-mail to the address**
jeancarlos.rios@iegexpo.it not later than **September 1st, 2018.**

D Teli fontana ingresso sud

Banners fountain south entrance

INGRESSO SUD N. - 2 Teli
SOUTH ENTRANCE DRIVE - N. 2 Banner

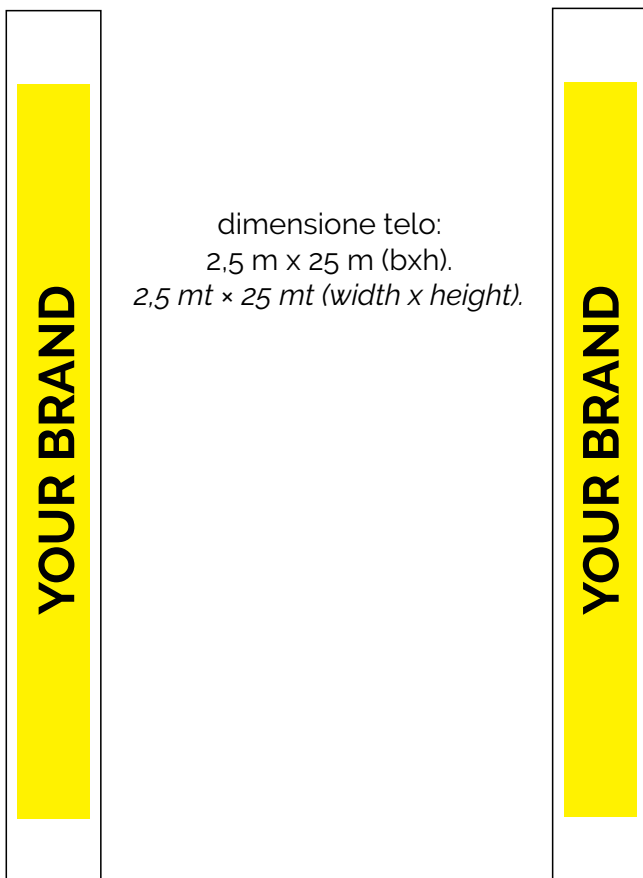

dimensione telo:
2,5 m x 25 m (bxh).
2,5 mt x 25 mt (width x height).

Visibilità del brand aziendale su teli posizionati sulle colonne poste ai lati della fontana dell'ingresso principale (ingresso sud).

Corporate brand visibility on onesided banners placed on the columns at the sides of the main entrance fountain (south entrance).

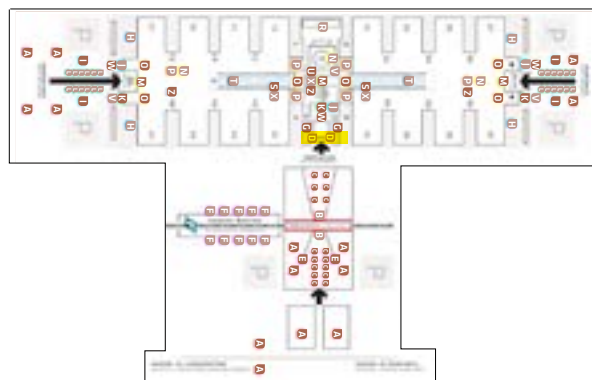

Quotazione / Price

€ 20.000,00

+ iva N. 2 Teli/Banners

Comprensivo di visibilità, produzione, posizionamento e rimozione.

Including visibility, production, placement and removal.



 *Clicca per ingrandire*
Click to enlarge

OPZIONA PRIMA DEGLI ALTRI IL TUO SPAZIO!
OPTION YOUR SPACE BEFORE OTHER!



Dimensione: **2,5 m x 25 m (bxh)**
Materiale grafico: **file in PDF alta risoluzione fornito dal cliente.**
Consegna materiale: **entro il 01 settembre 2018**
e-mail a: jeancarlos.rios@iegexpo.it

Size: **2,5 mt x 25 mt (width x height).**
Graphic materials: **High-resolution PDF file format supplied by the customer.**
Delivery of material: **By e-mail to the address**
jeancarlos.rios@iegexpo.it not later than **September 1st, 2018.**

E Telo pubblicitario sottopasso pedonale Underpass advertising banner

VIALE INGRESSO SUD
SOUTH ENTRANCE DRIVE

Personalizzazione dei
camminamenti del sottopasso
ferroviario che portano dal
parcheggio all'ingresso sud.

Personalisation of the
pedestrian underpass that
lead from the parking area to
the south entrance.

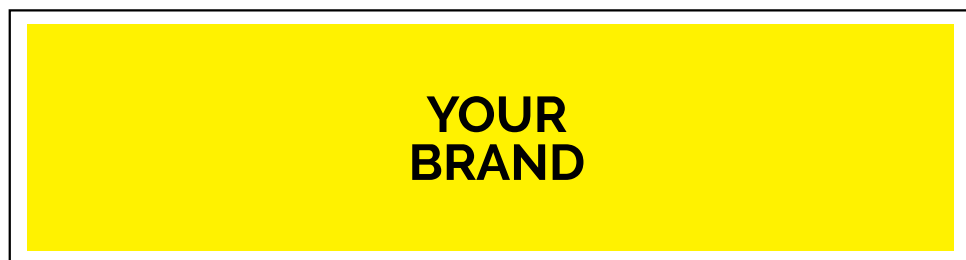

3,00 m x 0,90 m (bxh). per 41 pz • 123 mt lineari
123 mt x 0,9 mt (width x height).

Quotazione / Price

€ 3.000,00 cad.
each.

+ iva

N. 2 striscioni/maxi banners

Produzione, posizionamento e
rimozione a carico del cliente.

*Production, placement and removal is
exhibitor responsibility.*

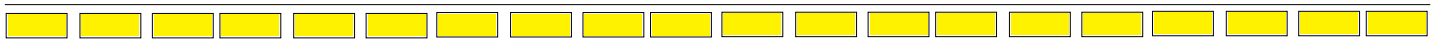

 *Clicca per ingrandire*
Click to enlarge

OPZIONA PRIMA DEGLI ALTRI IL TUO SPAZIO!
OPTION YOUR SPACE BEFORE OTHER!



pag_20

Dimensione: **123 mt x 0,9 m (bxh)**
Materiale grafico: **file in PDF alta risoluzione fornito dal cliente.**
Consegna materiale: **entro il 01 settembre 2018**
e-mail a: jeancarlos.rios@iegexpo.it

size: **123 mt x 0,9 mt (width x height).**
Graphic materials: **High-resolution PDF file format supplied
by the customer.**
Delivery of material: **By e-mail to the address
jeancarlos.rios@iegexpo.it not later than September 1st, 2018.**

F Totem bifacciali (stazione di Rimini Fiera)
Double-sided Billboard
(in Rimini Fiera train station)

STAZIONE FERROVIARIA INGRESSO SUD
RAILWAY STATION SOUTH ENTRANCE

Visibilità del brand aziendale
sulle plance bifacciali
posizionate nella fermata
Rimini Fiera.

Corporate brand visibility
double-sided panels
placed at the railway station
in Rimini Fiera stop.

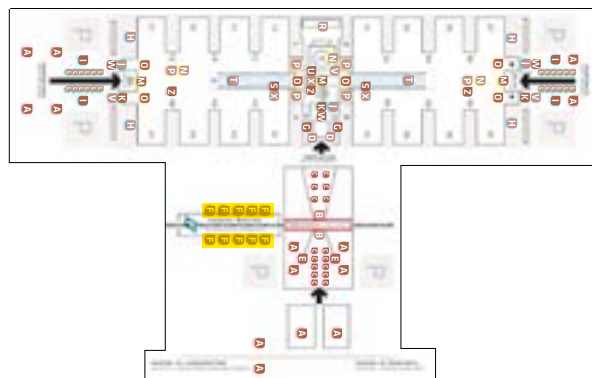

N. 8 Plance bifacciali
double side panel

Quotazione / Price

€ 1.000,00 cad.
each.

+ iva

Comprensivo di visibilità, produzione,
posizionamento e rimozione.

*Including visibility, production,
placement and removal.*



 *Clicca per ingrandire*
Click to enlarge

OPZIONA PRIMA DEGLI ALTRI IL TUO SPAZIO!
OPTION YOUR SPACE BEFORE OTHER!



Dimensione: **114 cm x 168 cm (bxh)**
Materiale grafico: **file in PDF alta risoluzione fornito dal cliente.**
Consegna materiale: **entro il 01 settembre 2018**
e-mail a: jeancarlos.rios@iegexpo.it

Size: **114 cm x 168 cm (width x height).**
Graphic materials: **High-resolution PDF file format supplied
by the customer.**
Delivery of material: **By e-mail to the address
jeancarlos.rios@iegexpo.it not later than September 1st, 2018.**

Teli palazzine ingresso sud South office building banner

INGRESSO SUD PALAZZINE UFFICI
SOUTH ENTRANCE OFFICE BUILDING

N. 4 Teli - Building banner

Visibilità del marchio aziendale sui teli posizionati sulla palazzina degli uffici ingresso sud.

Corporate brand visibility on one-sided banner on the south hall office building.

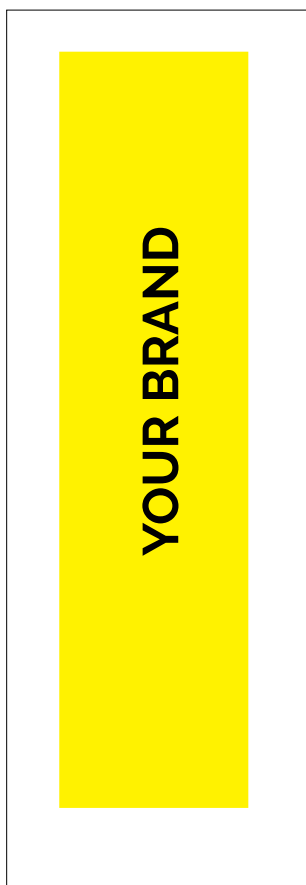

Quotazione / Price

€ 20.000,00 cad. each.

+ iva

Comprensivo di visibilità, produzione, posizionamento e rimozione.

Including visibility, production, placement and removal.

2,5 m × 10 m (bxh).
2,50 mt × 10 mt (width x height).



 *Clicca per ingrandire*
Click to enlarge

OPZIONA PRIMA DEGLI ALTRI IL TUO SPAZIO!
OPTION YOUR SPACE BEFORE OTHER!



pag_22

Dimensione: **2,5 m × h 10 m (bxh)**
Materiale grafico: **file in PDF alta risoluzione fornito dal cliente.**
Consegna materiale: **entro il 01 settembre 2018**
e-mail a: jeancarlos.rios@iegexpo.it

Size: **2,50 mt × 10 mt (width x height).**
Graphic materials: **High-resolution PDF file format supplied by the customer.**
Delivery of material: **By e-mail to the address jeancarlos.rios@iegexpo.it not later than September 1st, 2018.**

H Teli esterni ingressi West - east entrance banners

AREA ESTERNA INGRESSI EST-OVEST
EAST-WEST ENTRANCES OUTDOOR AREAS

N. 4 Teli esterni - Entrance banners

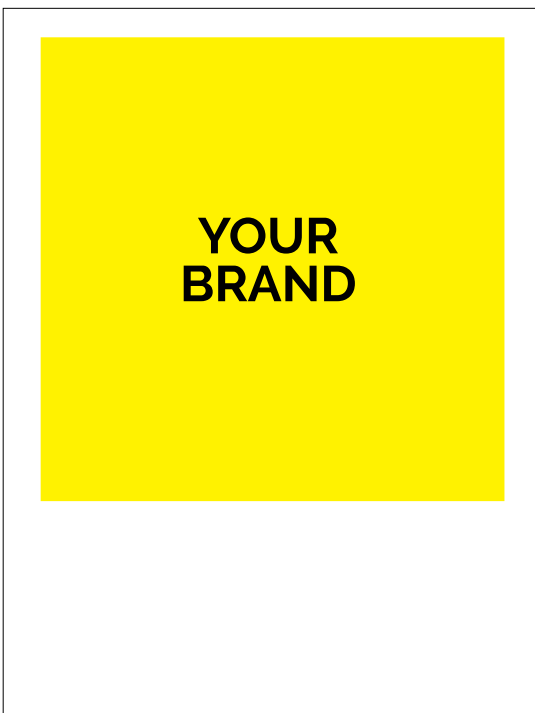

5 m × 5 m (bxh) • 5 mt × 5 mt (width x height).

Visibilità del brand aziendale su teli monofacciali posizionati sulle pareti laterali agli ingressi est e ovest.

Corporate brand visibility on one-sided banner placed on a side of the East and West entrance.

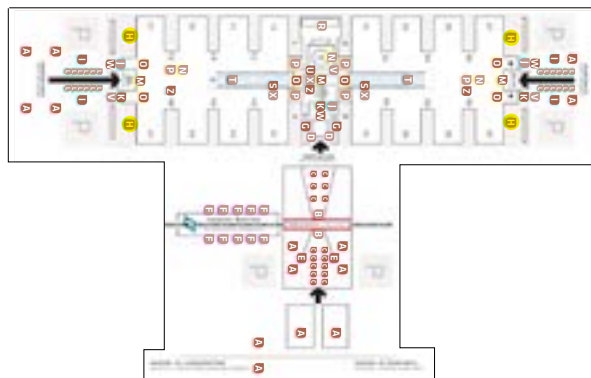

Quotazione / Price

€ 6.000,00 cad. each.

+ iva
n.2 ingresso Est
n.2 ingresso Ovest

Comprensivo di visibilità, produzione, posizionamento e rimozione.

Including visibility, production, placement and removal.



 *Clicca per ingrandire*
Click to enlarge

OPZIONA PRIMA DEGLI ALTRI IL TUO SPAZIO!
OPTION YOUR SPACE BEFORE OTHER!



pag_23

Dimensione: **5 m × 5 m (bxh)**
Materiale grafico: **file in PDF alta risoluzione fornito dal cliente.**
Consegna materiale: **entro il 01 settembre 2018**
e-mail a: jeancarlos.rios@iegexpo.it

Size: **5 mt × 5 mt (width x height).**
Graphic materials: **High-resolution PDF file format supplied by the customer.**
Delivery of material: **By e-mail to the address jeancarlos.rios@iegexpo.it not later than September 1st, 2018.**

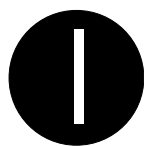

Aree interne ed esterne/gonfiabili

Internal and external areas/inflatables

Visibilità del brand-prodotto aziendale all'interno o all'esterno del quartiere fieristico.

Corporate brand visibility-advertisement in the external or internal fair areas.

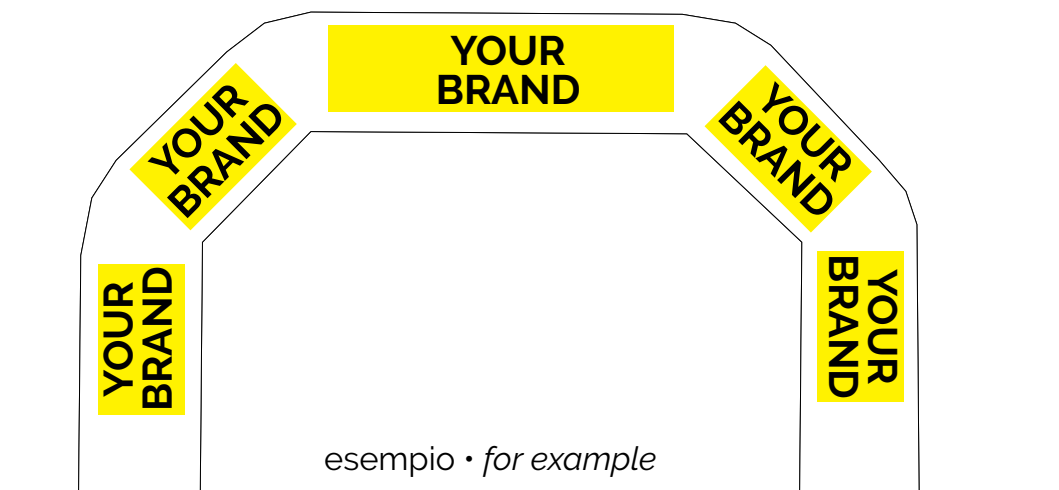

Quotazione / Price

€ 9.000,00 cad. each.

+ iva



 *Clicca per ingrandire*
Click to enlarge

OPZIONA PRIMA DEGLI ALTRI IL TUO SPAZIO!
OPTION YOUR SPACE BEFORE OTHER!



pag_24

Italian Exhibition Group mette a disposizione l'area per l'esposizione.
Produzione materiale, allaccio elettrico, e servizi sono a carico del cliente.

*Italian Exhibition Group provides bare area for exhibition.
Production, electricity and services are not included.*

Posizionamento / Placement: ottobre / October 8th, 2018
Rimozione / Removal: ottobre / October 13th, 2018

J Personalizzazione vetrate padiglioni Hall windows personalization

INGRESSI SUD-EST-OVEST PADIGLIONI
SOUTH-EAST-WEST ENTRANCES HALLS

Vetrate - Personalized window

Personalizzazione con grafica adesiva delle vetrate dei padiglioni che si affacciano sulle piscine interne. o sulle porte di collegamento tra i padiglioni.

Personalization with adhesive graphic of the pavilion windows facing the internal pools or the windows connection between halls.

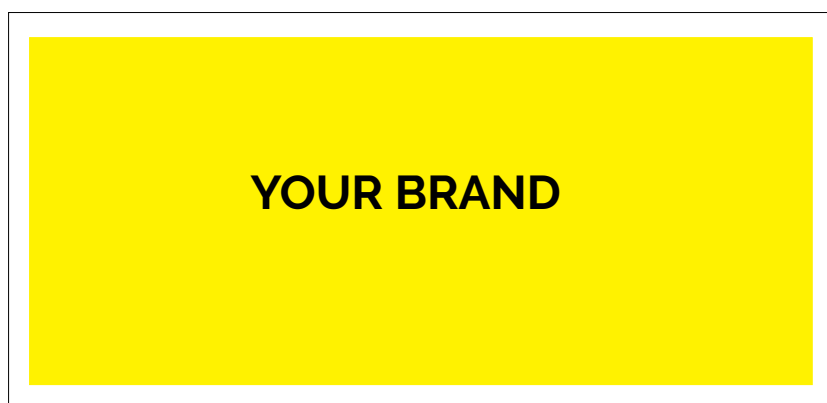

259 cm x 115 cm (bxh). • 259 cm x 115 cm (width x height).
252 cm x 102 cm (bxh). • 252 cm x 102 cm (width x height).

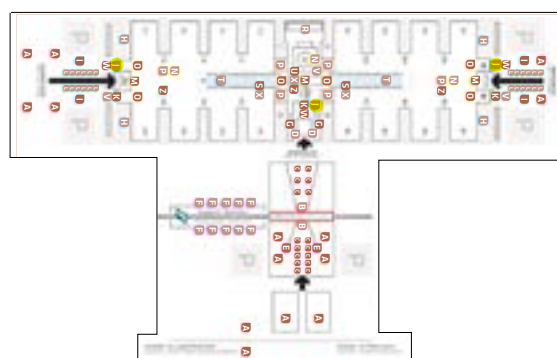

Quotazione / Price

Comprensiva di visibilità e stampa
Including visibility and printing.

VETRATE/WINDOWS

n. 10 Ingresso Est / East Entrance	€ 20.000	+ iva. - Cad/each
n. 10 ingresso Ovest/ West Entrance	€ 20.000	+ iva. - Cad/each
n. 16 Ingresso Sud/ South Entrance	€ 25.000	+ iva. - Cad/each
Padiglione/Pavilion	€ 1.500	+ iva. - Cad/each



 *Clicca per ingrandire*
Click to enlarge

OPZIONA PRIMA DEGLI ALTRI IL TUO SPAZIO!
OPTION YOUR SPACE BEFORE OTHER!



pag_25

Dimensione: **259 cm x 115 cm (bxh)**
Materiale grafico: **file in PDF alta risoluzione fornito dal cliente.**
Consegna materiale: **entro il 01 settembre 2018**
e-mail a: jeancarlos.rios@iegexpo.it

Size: **259 cm x 115 cm (width x height).**
Graphic materials: **High-resolution PDF file format supplied by the customer.**
Delivery of material: **By e-mail to the address**
jeancarlos.rios@iegexpo.it not later than **September 1st, 2018.**

Teli colonne interne Internal column banners

INGRESSI E AREE INTERNE
ENTRANCES AND INDOOR AREAS

Visibilità del brand aziendale
su teli verticali posizionati sulle
colonne interne.

Corporate brand visibility on
the internal vertical column
banners.



1 m x 7 m (bxh).
1 m x 5 m (bxh).
telo monofacciale.

100 cm x 700 cm
100 cm x 500 cm
(width x height).
one sided pvc panel.

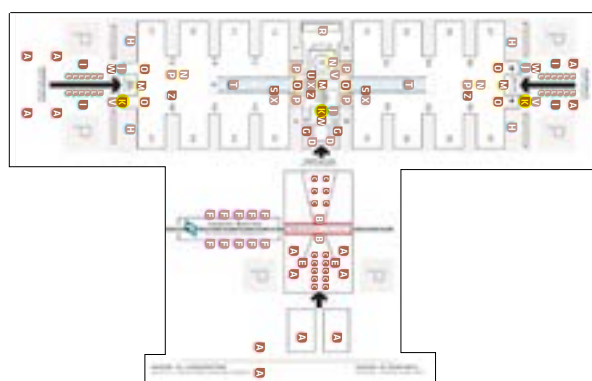

Quotazione / Price

€ 3.000,00 cad.
each.

+ iva

Comprendo di visibilità, produzione,
posizionamento e rimozione.

*Including visibility, production,
placement and removal.*



 *Clicca per ingrandire*
Click to enlarge

OPZIONA PRIMA DEGLI ALTRI IL TUO SPAZIO!
OPTION YOUR SPACE BEFORE OTHER!



Dimensione: **100 cm x 700 cm (bxh)** (telo monofacciale in pvc
Dimensione: **b 100 cm x h 500 cm** (telo monofacciale in pvc
Materiale grafico: **file in PDF alta risoluzione fornito dal cliente.**
Consegna materiale: **entro il 01 settembre 2018**
e-mail a: **jeancarlos.rios@iegexpo.it**

Size: 100 cm x 700 cm (width x height), one sided pvc panel
Size: 100 cm x 500 cm (width x height), one sided pvc panel
Graphic materials: High-resolution PDF file format supplied
by the customer.
Delivery of material: By e-mail to the address
jeancarlos.rios@iegexpo.it not later than September 1st, 2018.



Vele esterne ed interne

External and internal "sail" panel stands

AREE INTERNE ED ESTERNE
INDOOR AND OUTDOOR AREAS

N. 20 Vele esterne/interne-External/internal sails

Visibilità del brand aziendale
sulle vele esterne o interne
posizionate vicino agli ingressi
o lungo le piscine.

Corporate brand visibility
on external or internal sails
located near the entrances or
along the internal pools.



100 cm x 140 cm (bxh) • 100 cm x 140 cm (width x height).



Quotazione / Price

€ 5.000,00 4 vele
4 Sails

+ iva

Comprensivo di visibilità, produzione,
posizionamento e rimozione.

*Including visibility, production,
placement and removal.*



 *Clicca per ingrandire*
Click to enlarge

OPZIONA PRIMA DEGLI ALTRI IL TUO SPAZIO!
OPTION YOUR SPACE BEFORE OTHER!



pag_27

Dimensione: **100 cm x 140 cm (bxh)**.
Materiale gra ico: **file in PDF alta risoluzione fornito dal cliente**.
Consegna materiale: **entro il 01 settembre 2018**
e-mail a: jeancarlos.rios@iegexpo.it

Size: 100 cm x 140 cm (width x height)
*Graphic materials: High-resolution PDF file format supplied
by the customer.*
Delivery of material: By e-mail to the address
jeancarlos.rios@iegexpo.it not later than September 1st, 2018.

M Personalizzazione tornelli d'ingresso
Entrance turnstiles personalization

INGRESSI SUD-EST-OVEST
SOUTH-EAST-WEST ENTRANCES

Visibilità del brand aziendale
sulle vetrate e tornelli che
danno accesso alla fiera.

Corporate brande visibility on
the glass panels and turnstiles
to access the fair.

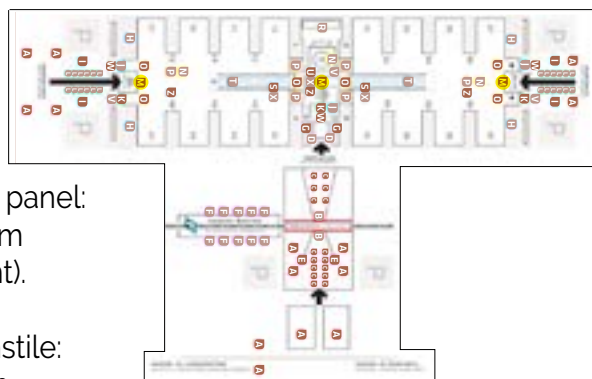
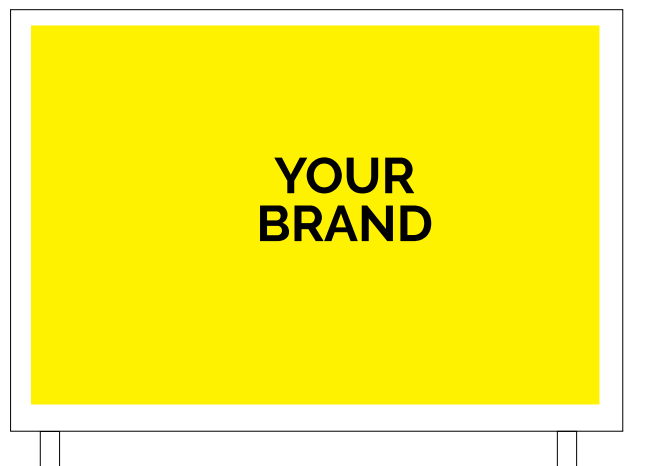

Vetrata/glass panel:
132 cm x 88 cm
(width x height).

Tornello/Turnstile:
63 cm x 10 cm
(width x height)



VETRATE+TORNELLI / WINDOWS+TURNSTILES

Quotazione / Price
Comprensiva di visibilità e stampa
including visibility and printing.

Ingresso ovest <i>West entrance</i>	€ 5.000 + iva. 3 tornelli / turnstiles + 4 vetrate / windows
Ingresso sud <i>South entrance</i>	€ 11.000 + iva. 6 tornelli / turnstiles + 8 vetrate / windows

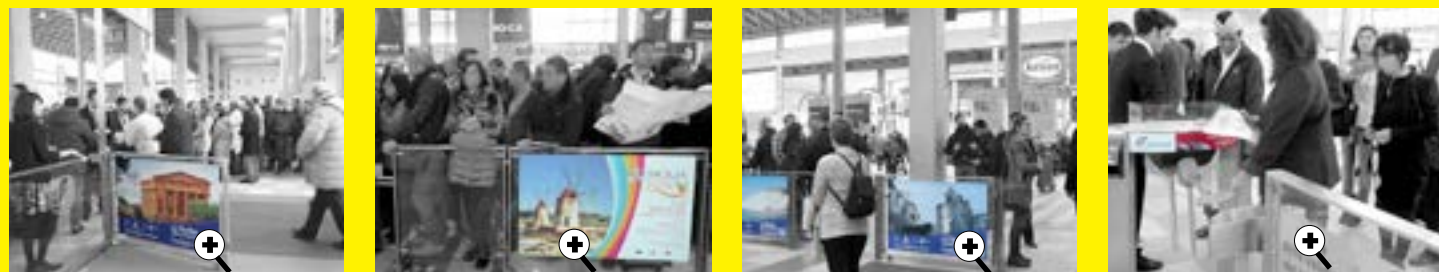

 *Clicca per ingrandire*
Click to enlarge

OPZIONA PRIMA DEGLI ALTRI IL TUO SPAZIO!
OPTION YOUR SPACE BEFORE OTHER!

Dimensione tornello: **63 cm x 10 cm (bxh)**.
Dimensione vetrata: **132 cm x 88 cm (bxh)**.
Materiale grafico: **file in PDF alta risoluzione fornito dal cliente.**
Consegna materiale: **entro il 01 settembre 2018**
e-mail a: **jeancarlos.rios@iegexpo.it**

Size turnstile: **63 cm x 10 cm (width x height)**
Size glass panel: **132 cm x 88 cm (width x height)**
Graphic materials: **High-resolution PDF file format supplied by the customer.**
Delivery of material: **By e-mail to the address jeancarlos.rios@iegexpo.it not later than September 1st, 2018.**

N Cigni interni Internal "swan" panel stands

INGRESSI SUD - OVEST - EST
ENTRANCE SOUTH - EAST- WEST

N. 12 Cigni interni - Internal "swan" panel stands

Visibilità del brand aziendale
sui cigni mobili posizionati
nella hall d'ingresso

Corporate brand visibility on
the Internal "swan" panel stands
located in the entrance halls.

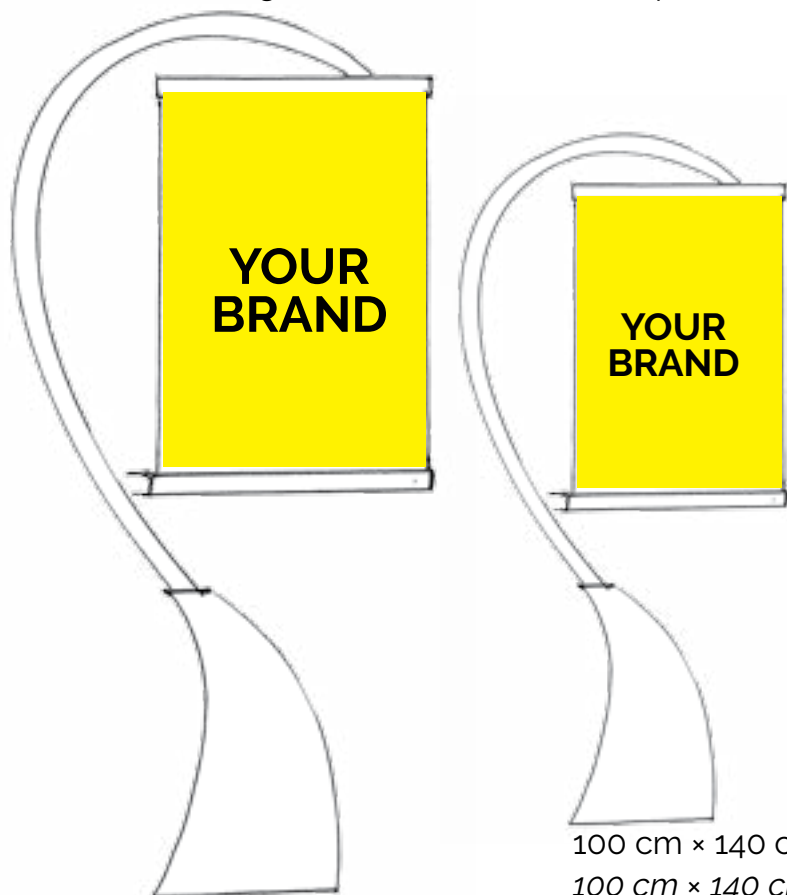

Quotazione / Price

€ 2.000,00

+ iva
N.2 cigni
n. 2 swan panel stands

Comprensivo di visibilità, produzione,
posizionamento e rimozione.

*Including visibility, production,
placement and removal.*

100 cm x 140 cm (bxh).

100 cm x 140 cm (width x height)



 *Clicca per ingrandire*
Click to enlarge

OPZIONA PRIMA DEGLI ALTRI IL TUO SPAZIO!
OPTION YOUR SPACE BEFORE OTHER!



Dimensione: **100 cm x 140 cm (bxh (telo bifacciale in pvc**
Materiale grafico: **file in PDF alta risoluzione fornito dal cliente**
Consegna materiale: **entro il 01 settembre 2018**
e-mail a: **jeancarlos.rios@iegexpo.it**

Size: 100 cm x 140 cm (width x height), double-sided pvc panel.
Graphic materials: High-resolution PDF file format supplied
by the customer.

Delivery of material: By e-mail to the address
jeancarlos.rios@iegexpo.it not later than September 1st, 2018.



Teli pubblicitari hall sud

South hall advertiing banners

INGRESSI SUD - OVEST - EST E HALL CENTRALE

ENTRANCE SOUTH - EAST- WEST AND CENTRAL FOYER

N. 4 Teli bifacciali - Double sided banners

Visibilità del brand aziendale
su teli bifacciali
posizionati nelle hall
posizionati nella hall sud.

Corporate brand visibility
on double-sided banners
positioned in the south hall.

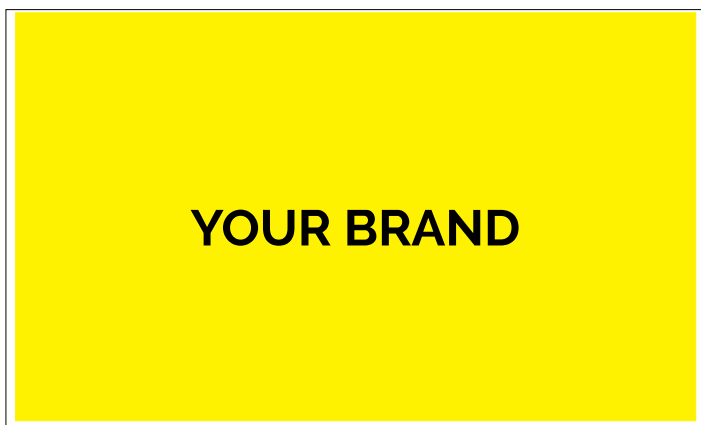

5 m × 3 m (bxh).

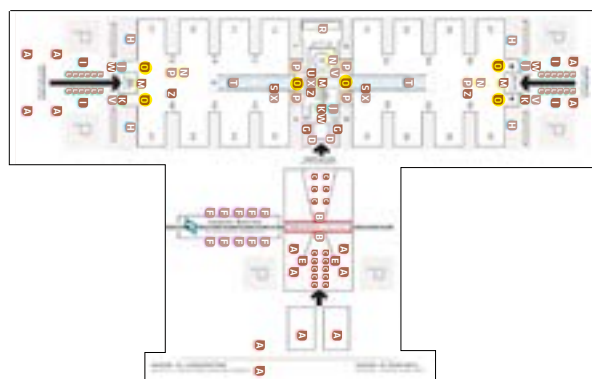

Quotazione / Price

€ 9.000,00 cad. each.

+ iva

Comprensivo di visibilità, produzione,
posizionamento e rimozione.

*Including visibility, production,
placement and removal.*



Clicca per ingrandire
Click to enlarge

OPZIONA PRIMA DEGLI ALTRI IL TUO SPAZIO!
OPTION YOUR SPACE BEFORE OTHER!



pag_30

Dimensione: **500 cm × 300 cm (bxh laterale (telo bifacciale in pvc**
Materiale grafico: **file in PDF alta risoluzione fornito dal cliente.**
Consegna materiale: **entro il 01 settembre 2018**
e-mail a: **jeancarlos.rios@iegexpo.it**

Size: **500 cm x 300 cm (width x height), side double-sided pvc panel**
Graphic materials: **High-resolution PDF file format supplied by the customer.**

Delivery of material: **By e-mail to the address**
jeancarlos.rios@iegexpo.it not later than September 1st, 2018.

P Teli pubblicitari area Caffè Coffee area advertising Banners

AREA BAR E NEGOZI INGRESSI - HALL CENTRALE
BAR AND SHOPPING AREA ENTRANCES
AND CENTRAL FOYER

N. 16 Teli monofacciali pvc - Single sided pvc banners

Visibilità del brand aziendale
su teli orizzontali posizionati
sopra i negozi e bar all'interno
del quartiere fieristico.

Corporate brand visibility on
horizontal banners located
above the shops and bar
located of the fair.

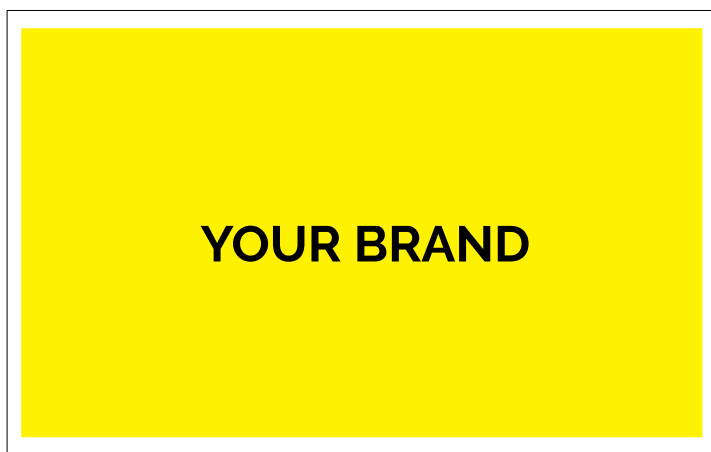

5,2 m x 3,6 m / 520 cm x 360 cm (width x height).

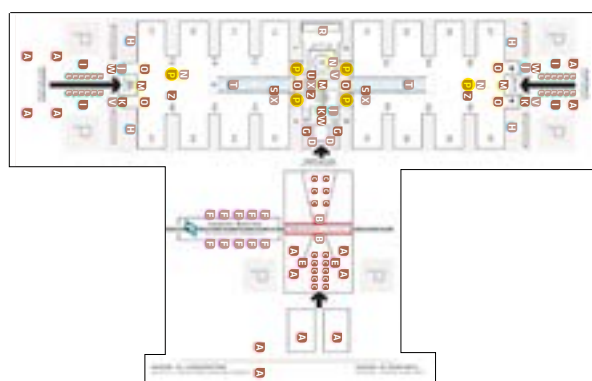

Quotazione / Price

€ 6.000,00 cad.
each.

+ iva

Comprendo di visibilità, produzione,
posizionamento e rimozione.

*Including visibility, production,
placement and removal.*



 *Clicca per ingrandire*
Click to enlarge

OPZIONA PRIMA DEGLI ALTRI IL TUO SPAZIO!
OPTION YOUR SPACE BEFORE OTHER!



pag_31

Dimensione: **520 cm x 360 cm (bxh). laterale**
(telo monofacciale in pvc)
Materiale grafico: **file in PDF alta risoluzione fornito dal cliente.**
Consegna materiale: **entro il 01 settembre 2018**
e-mail a: **jeancarlos.rios@iegexpo.it**

Size: 520 cm x 360 cm (width x height), single-sided pvc panel
Graphic materials: High-resolution PDF file format supplied
by the customer.
Delivery of material: By e-mail to the address
jeancarlos.rios@iegexpo.it not later than September 1st, 2018.

P₁ Adesivo area hall SUD
South hall floor sticker

Visibilità del marchio aziendale su un adesivo posizionato a terra nella zona accredito degli ingressi sud e ovest.

Corporate brand visibility on a floor sticker in the south and west halls.



Diametro 5 mt.
Diameter 5 mt.

Quotazione / Price

€ 5.000,00 Cad.
Each.

+ iva

Comprensiva di visibilità, produzione, posizionamento e rimozione.

Including visibility, production, placement and removal.



Dimensione: **diametro 5 mt.**

Materiale grafico: **file in PDF alta risoluzione fornito dal cliente.**

Consegna materiale: **via e-mail all'indirizzo jeancarlos.rios@iegexpo.it entro il 1 settembre 2018.**

Size: **Diameter 5 mt.**

Graphic materials: **High-resolution PDF file format supplied by the customer.**

Delivery of material: **By e-mail to the address**

jeancarlos.rios@iegexpo.it not later than september 1st, 2018.





Adesivi pubblicitari su pavimento

Adhesive floor graphics

AREE INTERNE / INDOOR AREAS

Posizionamento di adesivi lungo un percorso scelto dal cliente.

Personalization with adhesive graphic of route chosen by exhibitor.

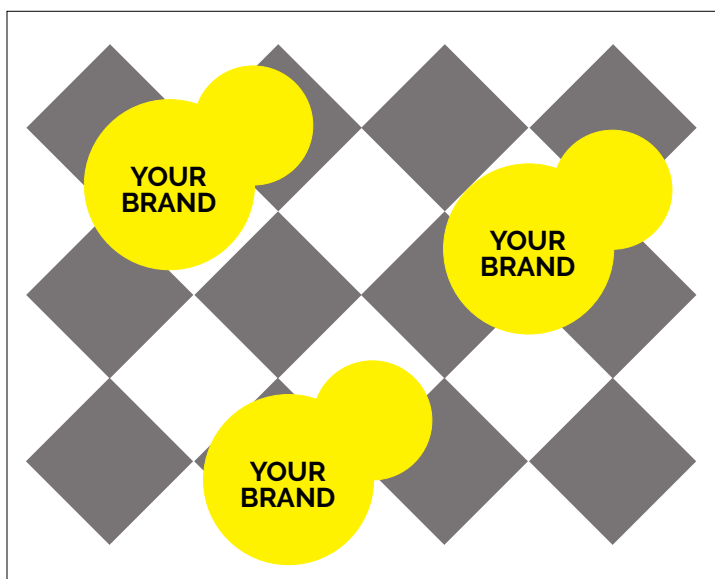

esempio • example

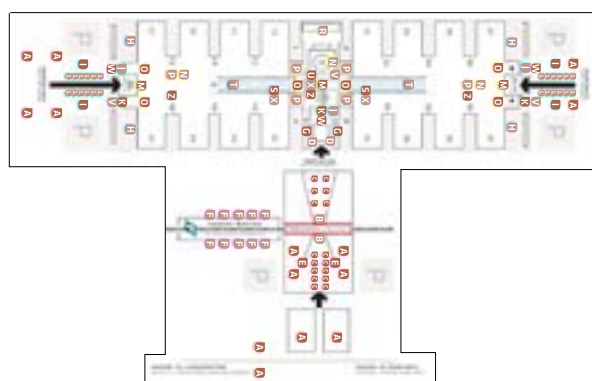

Quotazione / Price

**A RICHIESTA
ON REQUEST**

cad.
each.

+ iva

Comprensivo di visibilità, produzione, posizionamento e rimozione.

Including visibility, production, placement and removal.



 *Clicca per ingrandire*
Click to enlarge

OPZIONA PRIMA DEGLI ALTRI IL TUO SPAZIO!
OPTION YOUR SPACE BEFORE OTHER!



pag_33

Info percorso: il percorso è a scelta dell'espositore
info adesivo: adesivo 60 cm x 60 cm
Posizionamento: 1 adesivo ogni 3 metri.
Consegna materiale: entro il 1 settembre 2018
e-mail a: jeancarlos.rios@iegexpo.it

Route info: the route can be decided by the exhibitor.
Graphic info: Graphic 60 cm x60 cm
Application: 1 graphic every 3 m
Delivery of material: By e-mail to:
jeancarlos.rios@iegexpo.it no later than September 1st, 2018.

S Teli in pvc porticato piscine

Pool portico pvc banners

AREA PISCINE / POOL AREA

N. 4 teli pvc per porticato - Pool portico pvc banners

3 m x 5 m (bxh).

300 cm x 500 cm (width x height).

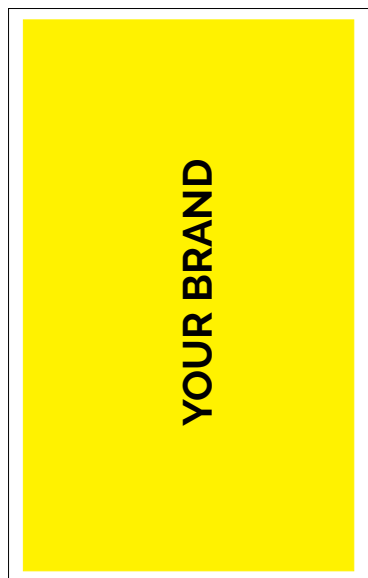

4 m x 2 m (bxh). Bifacciale.

4 mt x 2 mt (width x height). double sided.

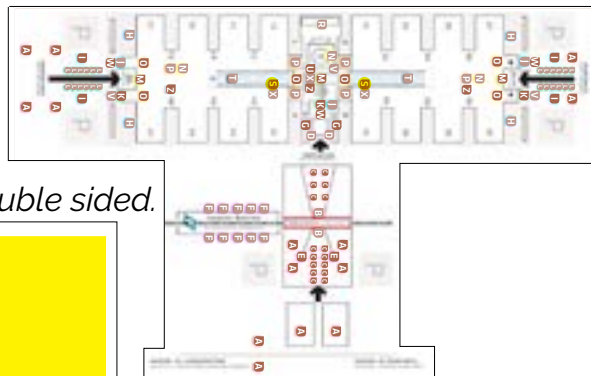
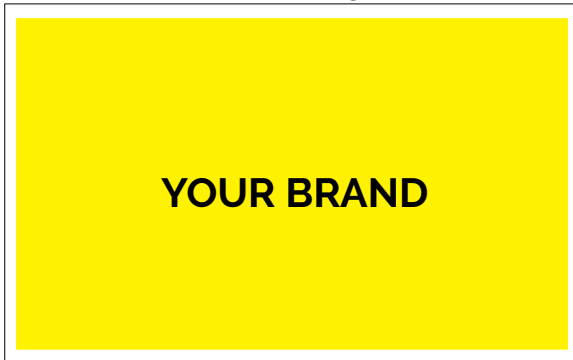

Visibilità del brand aziendale
su teli verticali posizionati
lungo i portici piscine.

Visibility of the corporate
brand of vertical sheets
positioned along the arcades
pools.

TELI IN PVC PORTICATO PISCINE POOL PORTICO PVC BANNERS

Quotazione / Price

3 m x 5 m (bxh). 300 cm x 500 cm (width x height). € 3.000,00 + iva. Cad/each

4 m x 2 m (bxh). 400 cm x 200 cm (width x height). € 5.000,00 + iva. Cad/each

Comprendivo di visibilità, produzione,
posizionamento e rimozione.

Including visibility, production,
placement and removal.



 *Clicca per ingrandire*
Click to enlarge

OPZIONA PRIMA DEGLI ALTRI IL TUO SPAZIO!
OPTION YOUR SPACE BEFORE OTHER!



Dimensione: 300 cm x 500 cm (bxh). (telo monofacciale in PVC)
Dimensione: 400 cm x 200 cm (bxh). (telo bifacciale in PVC)
Materiale grafico: file in PDF alta risoluzione fornito dal cliente.
Consegna materiale: entro il 01 settembre 2018
e-mail a: jeancarlos.rios@iegexpo.it

Size: 300 cm x 500 cm (width x height), single-sided PVC panel
Size: 400 cm x 200 cm (width x height), double-sided PVC panel
Graphic materials: High-resolution PDF file format supplied
by the customer.
Delivery of material: By e-mail to the address
jeancarlos.rios@iegexpo.it not later than September 1st, 2018.

S₁ Stendardo padiglione Banner pavilion



b 2,00 mt × h 4,50 mt Stendardo
PVC
2,00 mt × h 4,50 mt (width x height)
Banner pavilion PVC

Dimensioni: **b 2,00 mt × h 4,50 mt doppia asola superiore e inferiore da 10 cm.**
Materiale ammesso: **solo PVC.**
Consegna materiale:
file in formato pdf in alta risoluzione via e-mail all'indirizzo
jeancarlos.rios@iegexpo.it entro il 1 settembre, 2018.

Size: **2,00 mt × h 4,50 mt with double eyelets measuring 10 cm (width x height).**
Material allowed: PVC only.
Delivery of material: **send graphic artwork in pdf format by e mail to**
jeancarlos.rios@iegexpo.it, not later than September 1th, 2018

Visibilità del marchio aziendale
sugli stendardi bifacciali
posizionati sopra gli stand.

Corporate brand visibility on
double-sided banners to be
hung above the booth.

Quotazione / Price

€ 800,00 Cad.
Each.

+ iva
Comprensiva di visibilità,
posizionamento e rimozione
Invio e ritiro stendardo a carico
del cliente.

Including visibility, placement
and removal. Delivery and pick
up is customer responsibility

Quotazione / Price

€ 1.300,00 Cad.
Each.

+ iva
Comprensiva di visibilità,
produzione, posizionamento
e rimozione. Ritiro a carico del
cliente.
Including visibility, production,
placement and removal. Pick up
is customer responsibility.



T Piscine interne

Internal pools

PERSONALIZZAZIONE DELLE PISCINE INTERNE FRONTE
PADIGLIONI AC-BD / PERSONALISATION OF THE
INTERNAL POOLS IN FRONT OF PAVILIONS AC-BD.

N. 4 piscine interne -Internal pools

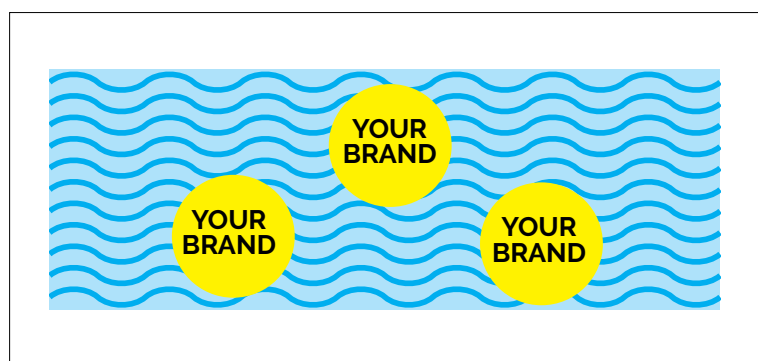

esempio • example

Dimensione piscina: 55 m x 13 m

altezza max 150 cm

Personalizzazione libera

Pool size: 55 m x 13 m

150 cm Maximum height for floating items

Free customization

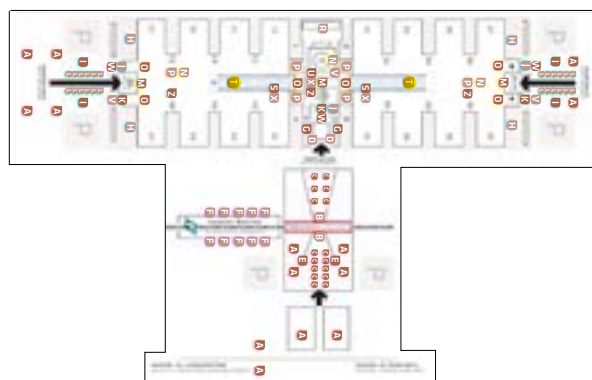

Quotazione / Price

€ 5.000,00 cad.
each.

+ iva

Comprendivo di visibilità. Produzione,
posizionamento e rimozione a
carico del cliente

*Including visibility. Production,
placement and removal is customer's
responsibility.*



 *Clicca per ingrandire*
Click to enlarge

OPZIONA PRIMA DEGLI ALTRI IL TUO SPAZIO!
OPTION YOUR SPACE BEFORE OTHER!



pag_36

Dimensione piscina: 55 m x 13 m
larghezza max 150 cm

Posizionamento: **entro il 9 ottobre 2018.**

Rimozione: **a partire dal 13 ottobre 2018.**

Pool size: 55 mt x 13 mt(width x height).

Maximum height for floating items: 150 cm

*Placement: **Not later than October 9th, 2018***

*Removal: **Starting from October 13th, 2018***

U Spot pubblicitario su maxischermo

Advertising spot on videowall

HALL CENTRALE E AREE SELF-SERVICE A6-C6
CENTRAL FOYER AND SELF-SERVICE AREAS A6-C6

Trasmissione a rotazione di uno spot pubblicitario su un circuito di maxischermi posizionati nella hall centrale e aree self service.

Promotional video on a video walls circuit located at the main hall and self service areas.

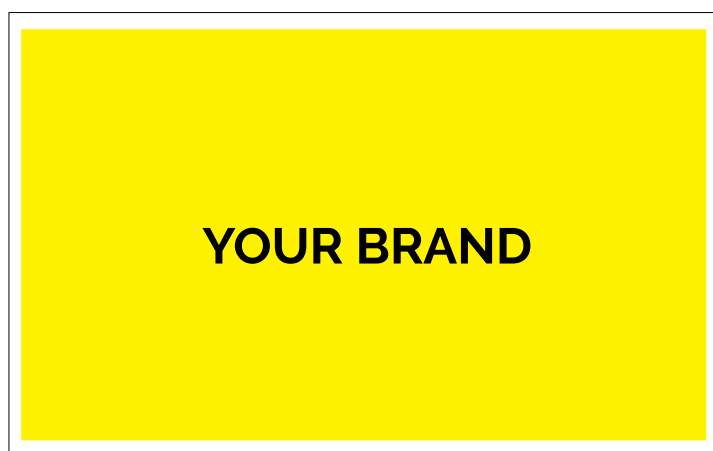

5 m x 3 m (bxh) / 5 mt x 3 mt (width x height)

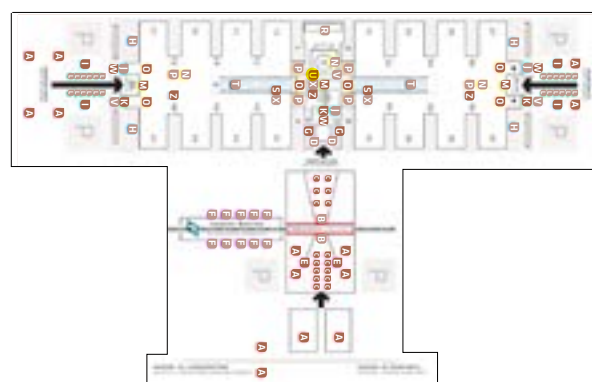

Quotazione / Price

€ 1.000,00 cad. each.

+ iva

Comprendivo di visibilità, caricamento video e prove tecniche di trasmissione

Including visibility, video loading and practice transmission.



 *Clicca per ingrandire*
Click to enlarge

OPZIONA PRIMA DEGLI ALTRI IL TUO SPAZIO!
OPTION YOUR SPACE BEFORE OTHER!



pag_37

Passaggio spot: 40 passaggi al giorno ca;
Durata video: **massimo 20 secondi**;
Dimensione videowall: **5 m x 3 m (bxh)**.
Formato materiale: **.avi - Produzione video a carico del cliente.**
Consegna materiale: **entro il 15 settembre 2018**
e-mail a: **jeancarlos.rios@iegexpo.it**

Central foyer mega-screen and professional monitor circuit.
Broadcast: 40 circa times a day.
Spot length: Up to 20 seconds.
Delivery of material: By e-mail to the address
jeancarlos.rios@iegexpo.it
not later than September 15th, 2018



Personalizzazione scalinate

Stair branding

Fair entrance and south hall steps personalisation

Visibilità del marchio aziendale sui gradini delle scale della hall sud che portano all'ufficio stampa e alle sale convegni. e Personalizzazione dei gradini degli ingressi della fiera.

Corporate brand visibility on the south hall steps that lead the press office and conference rooms. And personalization of the fair entrance steps.

GRADINI SALE CONVEGNI STEPS MEETING ROOMS



295 cm × 15 cm (bxh); gradini: n. 27.
295 cm × 15 cm steps: n. 27.

GRADINI INGRESSI ESTERNI STEPS EXTERNAL ENTRANCE



dimensione 10cmx40cm (widthxdeep).
N. 4 gradini/steps

Quotazione / Price

<i>scale convegni/ conference stair</i>	€ 5.000,00	cad. each + iva
<i>scale ingressi fiera/ expo entrance stairs</i>	€ 15.000,00	cad. each + iva

Comprensiva di visibilità, produzione, posizionamento e rimozione

Including visibility, production, placement and removal.

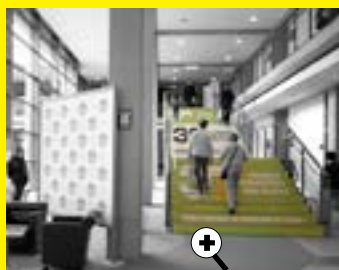

 *Clicca per ingrandire*
Click to enlarge

OPZIONA PRIMA DEGLI ALTRI IL TUO SPAZIO!
OPTION YOUR SPACE BEFORE OTHER!



Materiale grafico: **file in PDF alta risoluzione fornito dal cliente.**
Consegna materiale: **entro il 01 settembre 2018**
e-mail a: jeancarlos.rios@iegexpo.it

Graphic materials: High-resolution PDF file format supplied by the customer.

Delivery of material: By e-mail to the address jeancarlos.rios@iegexpo.it not later than September 1st, 2018.



Personalizzazioni porte girevoli Swing door branding

Ingresso sud/South entrance: N. 4 porte/doors

Ingresso est e ovest/East and West entrance: N. 2 porte/doors

Personalizzazione con grafica adesiva delle porte girevoli di ingresso alla fiera.

Corporate brand visibility on promotional double-sided graphics applied on the swing entrance doors.



220 cm x 136 cm (bxh)

grafica adesiva

220 cm x 136 cm (width x height)

adhesive graphic

4 facciate per porta/4 side per door



PORTE VETRATE GLASS DOORS

Quotazione / Price
Ad ingresso / for entrance

€ 20.000,00

+ iva

Comprensiva di visibilità, produzione, posizionamento e rimozione

Including visibility, production, placement and removal.



 *Clicca per ingrandire*
Click to enlarge

OPZIONA PRIMA DEGLI ALTRI IL TUO SPAZIO!
OPTION YOUR SPACE BEFORE OTHER!



pag_39

Dimensione: **220 cm x 136 cm (bxh - grafica adesiva)**
Materiale grafico: **file in PDF alta risoluzione fornito dal cliente.**
Consegna materiale: **entro il 01 settembre 2018**
e-mail a: jeancarlos.rios@iegexpo.it

Size: **220 cm x 136 cm (width x height) - adhesive graphic**
Graphic materials: **High-resolution PDF file format supplied by the customer**
Delivery of material: **By e-mail to the address**
jeancarlos.rios@iegexpo.it **not later than September 1st, 2018.**



Personalizzazione colonne interne Internal columns personalisation

Visibilità del brand aziendale sulle colonne posizionate negli ingressi principali, e nei portici piscine interne. Personalizzazione con grafica adesiva o cartelli pubblicitari.

Corporate brand visibility on the columns located in the entrance halls and along the pools. Personalization with adhesive graphic or advertising panels.

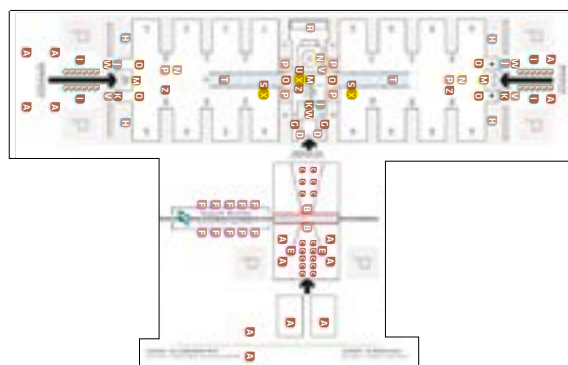

Cartello: 52x 300 cm (bxh).
Adesivo: 125.6 x 300 cm (bxh).
4-sided panel: 52 x 300 cm (width x height)
Adhesive graphic: 125.6 x 300 cm (width x height)

Quotazione / Price

Cad /colonne interne/each. - internal columns	€ 3.000,00 + iva
5 colonne - portico piscine/5 columns - porch pools	€ 5.000,00 + iva

Comprensiva di visibilità, produzione, posizionamento e rimozione

Including visibility, production, placement and removal.



Clicca per ingrandire
Click to enlarge

OPZIONA PRIMA DEGLI ALTRI IL TUO SPAZIO!
OPTION YOUR SPACE BEFORE OTHER!



pag_40

DIMENSIONI/SIZE:

Colonne ingressi/Entrance columns:
dimensione: 52x300cm bxh/Size: 52x300 cms (widexdeep)

Colonne portici piscine/Pool porch columns:
Dimensione: b 100 cm x h 150 cm - cartello bifacciale
Size: 100 x 150 cms (widexdeep) - double-sided panel

Grafica adesiva/adhesive graphic:
Dimensione: 125.6x300cm bxh/ Size: 125.6 x 300 cms (widexdeep)

Materiale grafico: file in PDF alta risoluzione
Graphic material: high resolution PDF file
Consegna materiale: entro il 01 settembre 2018

e-mail a: jeancarlos.rios@iegexpo.it
Delivery of material: By e-mail to the address jeancarlos.rios@iegexpo.it
not later than September 1th, 2018.

Catalogo-logo e pagine pubblicitarie

Catalogue-logo and advertising pages

Promozione di una pagina pubblicitaria all'interno del catalogo espositori.

Promotion of advertising page on the exhibitors catalogue.



Pagina int./Internal page

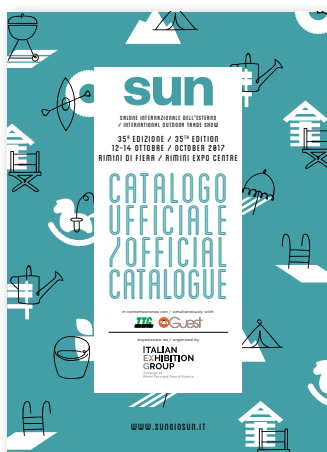

Catalogo /Catalogue

Quotazione / Price

Comprensiva di visibilità e stampa
including visibility and printing.

Prime Pagine/Head Pages **€ 1.400** + iva. - Cad/each

PAGINE INTERNE/INTERNAL PAGES

Pagina singola /single page **€ 1.000** + iva. - Cad/each

Doppia pagina int./double internal page **€ 1.800** + iva. - Cad/each

I romana/facing first right-hand page **€ 1.850** + iva. - Cad/each

Il di copertina/inside cover **€ 3.500** + iva.

Logo + presentazione/Logo + presentation **€ 800** + iva. - Cad/each

Materiale grafico: **file in PDF in alta risoluzione**
Dimensione **15 cm x 21 cm (verticale)**
Risoluzione **300 dpi font incluse nel PDF**
Abbondanza pagina **almeno 3 mm su ciascun lato**
(dimensione complessiva pagina 15,6 cm x 21,6 cm)
Spazio colore **CMYK**.
Consegna materiale: **entro il 01 settembre 2018**
e-mail a: **jeancarlos.rios@iegexpo.it**

Graphic materials: **Page format 15 cm x 21 cm (vertical)**
digital file format in PDF
Resolution of images **300 dpi font included in the PDF file**
Page layout **at least 3 mm on all four sides**
(total size: 15,6 cm x 21,6 cm)
Colour space **CMYK**.
Delivery of material: **By e-mail to the address**
jeancarlos.rios@iegexpo.it not later than September 1st, 2018.



Pianta Guida Guide Map

Visibilità logo sponsor sulla mappa guida di manifestazione.
Personalizzazione delle cover; del header e footer.

Sponsor's logo visibility on the Guide map of exhibition.
Personalisation of the header or footer banner; Personalisation of a cover.

Testatina/Header



YOUR BRAND

Piede/footer

COPERTINA/COVER
Fronte

COPERTINA/COVER
Retro

YOUR BRAND



INTERNAL COVER

COPERTINA/COVER

Quotazione / Price

Comprensiva di visibilità e stampa
including visibility and printing.

Testatina/piede	€ 2.200 + iva. - Cad./each
Logo	€ 1.200 + iva. - Cad./each
Copertina/Cover (interna/internal)	€ 2.500 + iva. - Cad./each
Copertina/Cover (esterna/external)	€ 3.000 + iva. - Cad./each

COPERTINA E BANNER

Materiale grafico: **logo formato vettoriale**
Misure: **banner 3,05 x 94 cm**
cover 10,05 x 24cm Interno/esterno
Consegna materiale: **entro il 01 settembre 2018**
e-mail a: jeancarlos.rios@iegexpo.it

COVER AND BANNER

Graphic materials: **logo vectorial format**
Size: **banner 3,05 x 94 cm; cover 10,05 x 24 cm**
Delivery of material: **By e-mail to the address**
jeancarlos.rios@iegexpo.it **not later than September 1st, 2018.**



Cordini e porta badge Lanyards and badge holder

Visibilità del marchio aziendale sui
cordini porta badge visitatori ed
espositori.

Corporate brand visibility on the
lanyards that will be distributed
to all of the trade visitors and
exhibitors.



Materiale grafico: **il progetto grafico deve comprendere anche il logo SUN BEACH&OUTDOOR STYLE. Prima della stampa deve essere approvato da Rimini Fiera e dallo sponsor.**

Se a carico di Rimini Fiera: **file in PDF alta risoluzione fornito dal cliente, da inviare via e-mail a jeancarlos.rios@iegexpo.it entro il 1 agosto 2018.**

Graphic materials: **SUN BEACH&OUTDOOR STYLE and Sponsor's logo will be printed together. The Graphic must be approved by Rimini Fiera.**

Rimini Fiera's production: **Send graphic material by e-mail to the address jeancarlos.rios@iegexpo.it not later than August 1, 2018.**

Quotazione / Quotation

**SU RICHIESTA
ON DEMAND**

+ iva

produzione, posizionamento e distribuzione.

Including visibility, placement and distribution.



Borse visitatori Visitors bags



Visibilità del marchio aziendale
sulle borse visitatori distribuite
presso gli info point
della manifestazione.

Corporate brand visibility
of visitors bags that will be
distributed at the info points.

Quotazione / Price

€ 5.000,00

+ iva

Comprensiva di visibilità.
Produzione a carico del cliente.

Including visibility. Production is
customer responsibility.

Materiale grafico: **le borse dovranno comprendere anche il logo SUN BEACH&OUTDOOR STYLE**
È necessario l'invio del file per approvazione prima della stampa a IEG SpA.
Consegna materiale: **01 ottobre 2018**

Graphic materials: **SUN BEACH&OUTDOOR STYLE**
and Sponsor's logo will be printed together.
Graphic must be approved by IEG SpA.
Delivery of material: **within October 1st, 2018**



Programma eventi Events programme

Promozione di una pagina pubblicitaria all'interno del programma eventi.

Promotion of a page on the events programme.



Pagina pubblicitaria nel programma eventi
Advertising page in the events programme

Quotazione / Price

Comprensiva di visibilità e stampa
including visibility and printing.

2 ^a di copertina / Inside front cover	€ 3.500 + iva. - Cad./each
3 ^a di copertina / Inside back cover	€ 3.000 + iva. - Cad./each
4 ^a di copertina / Outside cover	€ 5.000 + iva. - Cad./each
Doppia pagina interna / Double internal pages	€ 1.500 + iva. - Cad./each

Materiale grafico: file in PDF in alta risoluzione; dimensione 210x297 mm (verticale); risoluzione 300 dpi; font incluse nel PDF; abbondanza pagina almeno 3 mm in più su ciascun lato (dimensione complessiva pagina 213x300 mm; spazio colore CMYK.

Consegna materiale: via e-mail all'indirizzo jeancarlos.rios@iegexpo.it entro il 1 settembre 2018.

Graphic materials: Page format 210x297 mm (vertical); digital file format in PDF; resolution of images 300 dpi; font included in the PDF file, Page layout at least 3 mm on all four sides (total size: 213x300 mm); colour space CMYK.

Delivery of material: By e-mail to the address jeancarlos.rios@iegexpo.it not later than September 1st, 2018.



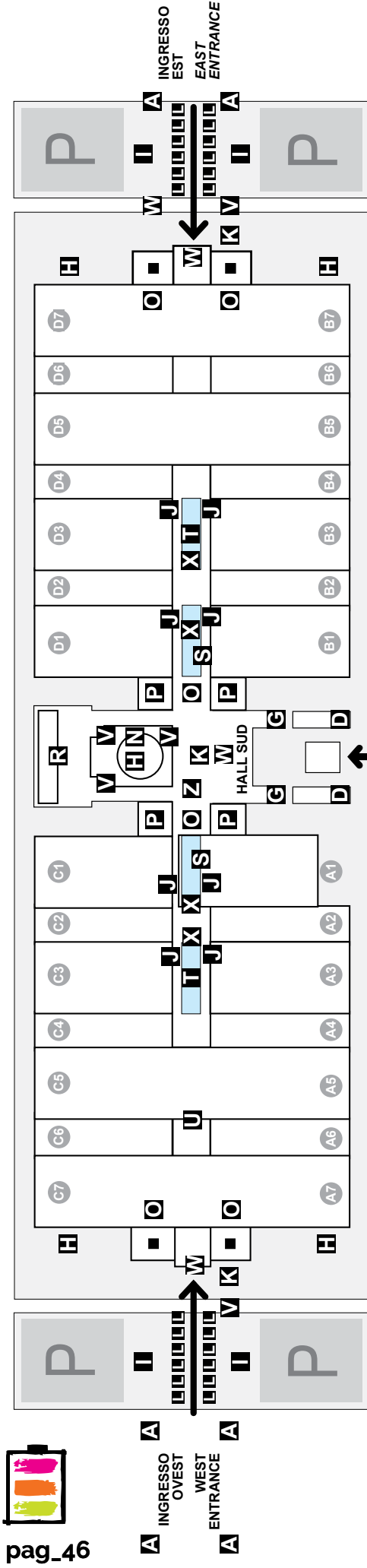

- A** Pannelli rotanti esterni Revolving panels
- B** Telo ponte ferrovia Railway bridge banner
- C** Cigni esterni External "swan" panel stands
- D** Teli fontana ingresso SUD Banner fountain south entrance
- E** Telo pubblicitario sottopasso pedonale Underpass advertising banner
- F** Totem bifacciali (stazione di Rimini Fiera) Double-sided Totem (in Rimini Fiera train station)
- G** Teli palazzine ingresso sud South office building banner
- H** Teli ingresso Est-ovest East-west entrance Banner
- I** Aree interne ed esterne/gonfiabili Internal and external areas/inflatables
- J** Personalizzazione vetrate padiglioni Pavilions Windows personalization
- K** Teli colonne esterne ed interne External and internal column banners
- L** Vele esterne ed interne External and Internal "sail" panel stands
- M** Personalizzazione tornelli d'ingresso Entrance Turnstiles personalization
- N** Cigni interni Internal "swan" panel stands
- O** Teli pubblicitari hall sud South hall advertising banners
- P** Teli pubblicitari area Caffè Coffee area advertising Banners
- P₁** Adesivo area hall sud South hall floor sticker
- Q** Adesivi pubblicitari su pavimento Adhesive floor graphics
- S** Teli in pvc Porticato piscine Pool portico Pvc banners
- S₁** Stendardo padiglione Banner Pavilion
- T** Piscine interne Internal pools
- U** Spot pubblicitario su maxischermo Advertising spot on videowall
- V** Personalizzazione scalinate Step/stair branding
- W** Personalizzazioni porte girevoli Swing door branding
- X** Personalizzazione colonne Column branding
- Z** Teli verticali esterni ed interni External and internal vertical banners

A via Emilia - dirz. casello Rimini Nord

via Emilia - dirz. Rimini Centro



SUN

BEACH&OUTDOOR STYLE

www.sungiosun.it



PLANiSPHERE
The Italian marketplace for travel & hospitality

 **Planisphere**
Via Emilia 155 - 47921 - Rimini (Italia)

Uffici Milano
Foro Buonaparte, 74
Tel. 02 806892
info@iegexpo.it
salessia@iegexpo.it

ORGANIZZATO DA
ITALIAN EXHIBITION GROUP
Providing the future

Sede
ITALIAN EXHIBITION GROUP SpA
Via Emilia 155 - 47921 - Rimini (Italia)